

# ***EOLO Star 23 kW***

***Instantaneous wall-hung  
with room-sealed boilers***



S.C. FUTURE LINE INSTAL S.R.L  
str. Biharia nr.67-77, sector 1, Bucuresti, ROMANIA

**serviceimmergas.ro**

**Dispecerat Non Stop  
Tel. Fix : 021-201.11.14**





service centrale - instalatii - autorizatii ISCIR

# EOLO Star 23 kW

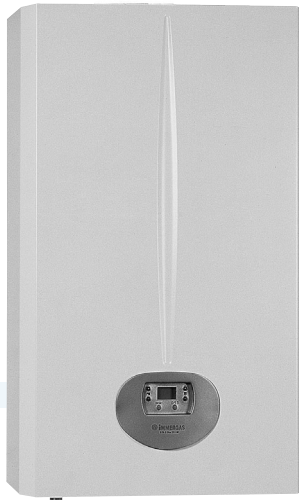

Compact instantaneous wall-hung room-sealed (type C) fan-assisted boiler.

## EOLO Star 23 kW

### General features.

EOLO Star 23 kW is a wall-hung, room-sealed fan-assisted boiler for heating and production domestic hot water. This very compact boiler (H=785 mm, W=450 mm, D=250 mm), has an output heat of 23.3 kW (20,000 kcal/h). A microprocessor controlled electronic board adjusts and controls the appliance (*burner ignition, temperature adjustment, flame modulation and diagnostics*) and, by means of a digital interface with display and push buttons, the operating parameters can be displayed and set.

The hydraulic circuit is equipped with a copper bithermal type water-gas exchanger for the production of hot water for central heating and domestic use, an automatic by-pass on the system and a flow switch for tapping the domestic hot water. Combustion air intake inside the sealed chamber and the expulsion of gases are ensured by a fan. A differential pressure switch controls correct operation.

### Main dimensions and main connections.

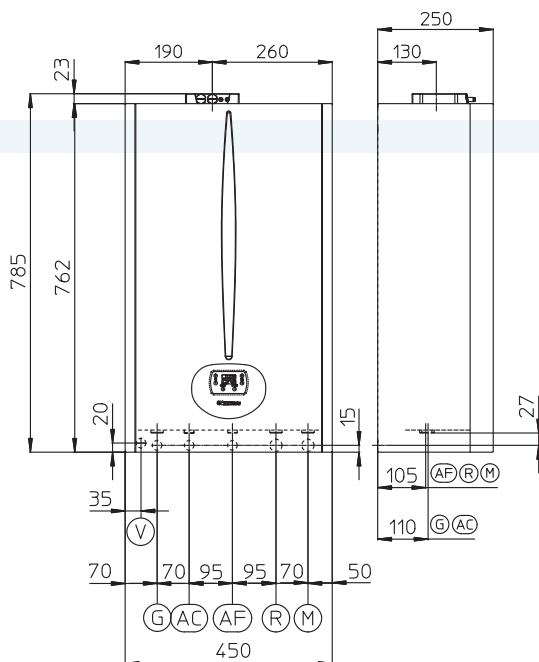

Height (mm)	Width (mm)	Depth (mm)		
785	450	250		
CONNECTIONS				
GAS	DOMESTIC CIRCUIT WATER		SYSTEM	
G	AC	AF	R	M
3/4"	1/2"	1/2"	3/4"	3/4"

- Legend:
- G - Gas supply
  - AC - Hot water outlet
  - AF - Cold water inlet
  - R - System return
  - M - System delivery
  - V - Electrical supply

**Main components.**

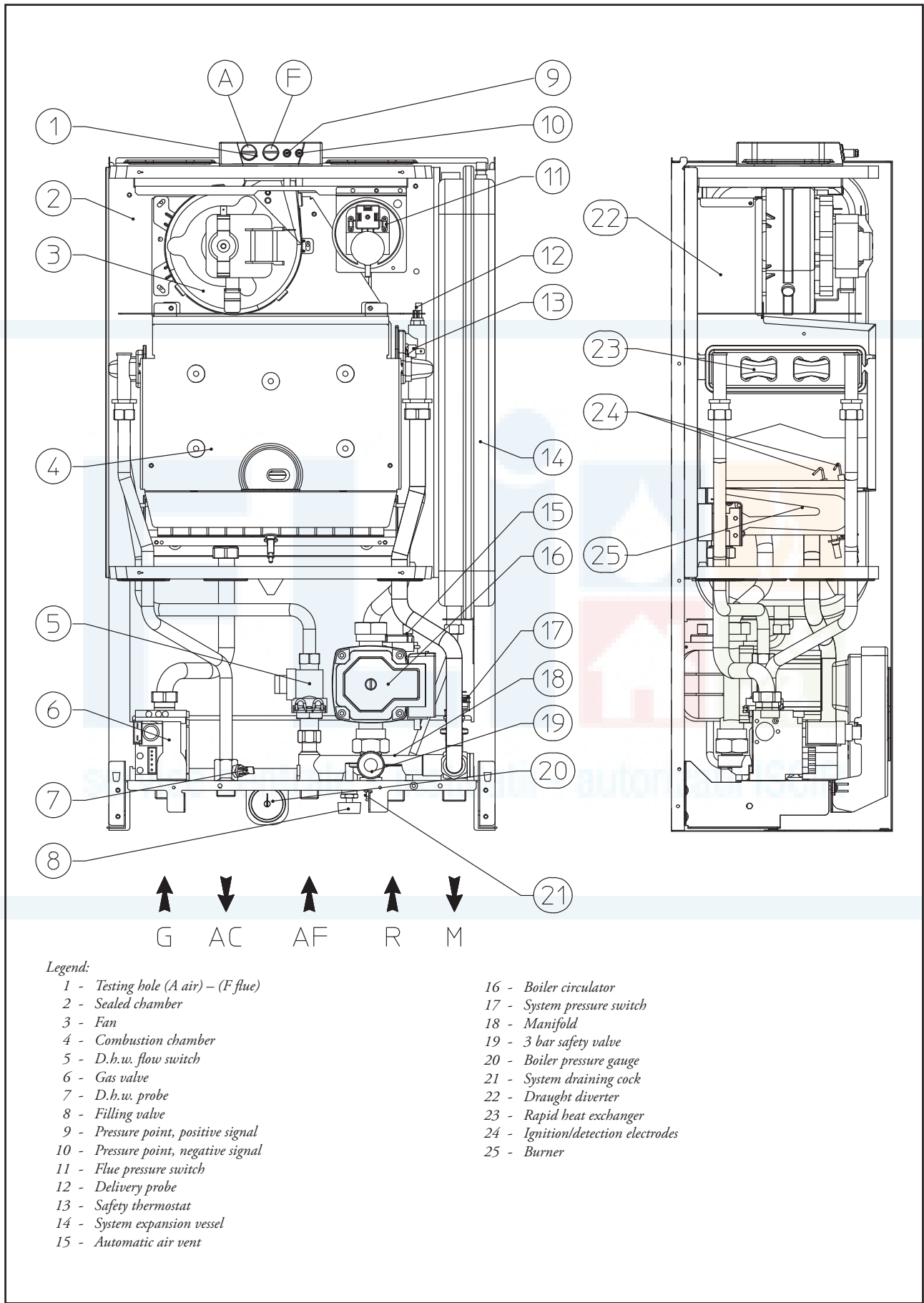

*Legend:*

- 1 - Testing hole (A air) – (F flue)
- 2 - Sealed chamber
- 3 - Fan
- 4 - Combustion chamber
- 5 - D.h.w. flow switch
- 6 - Gas valve
- 7 - D.h.w. probe
- 8 - Filling valve
- 9 - Pressure point, positive signal
- 10 - Pressure point, negative signal
- 11 - Flue pressure switch
- 12 - Delivery probe
- 13 - Safety thermostat
- 14 - System expansion vessel
- 15 - Automatic air vent

- 16 - Boiler circulator
- 17 - System pressure switch
- 18 - Manifold
- 19 - 3 bar safety valve
- 20 - Boiler pressure gauge
- 21 - System draining cock
- 22 - Draught diverter
- 23 - Rapid heat exchanger
- 24 - Ignition/detection electrodes
- 25 - Burner

**Control panel.**

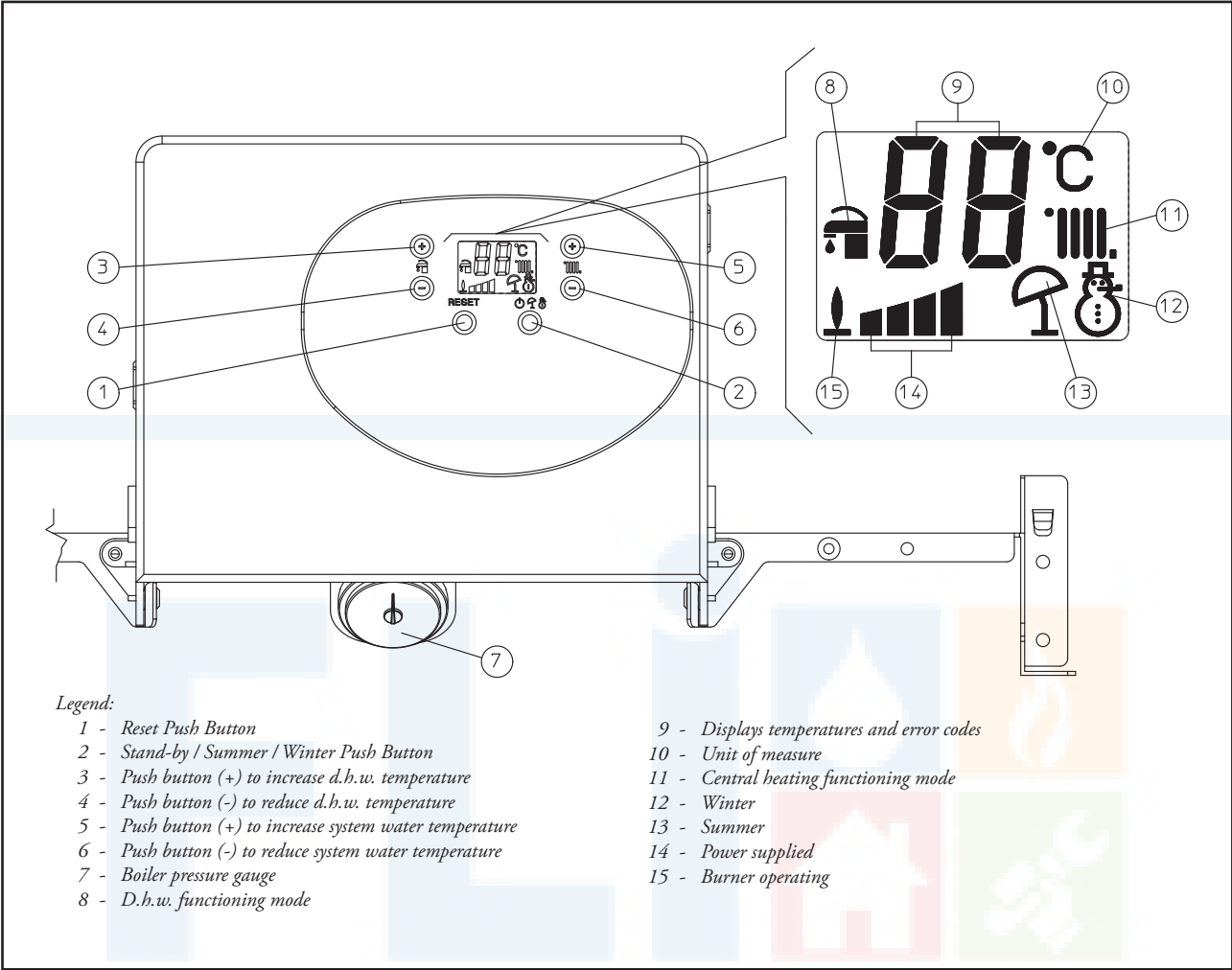

*Legend:*

- |  |   |
|--|---|
| 1 - Reset Push Button                                    | 9 - Displays temperatures and error codes |
| 2 - Stand-by / Summer / Winter Push Button               | 10 - Unit of measure                      |
| 3 - Push button (+) to increase d.h.w. temperature       | 11 - Central heating functioning mode     |
| 4 - Push button (-) to reduce d.h.w. temperature         | 12 - Winter                               |
| 5 - Push button (+) to increase system water temperature | 13 - Summer                               |
| 6 - Push button (-) to reduce system water temperature   | 14 - Power supplied                       |
| 7 - Boiler pressure gauge                                | 15 - Burner operating                     |
| 8 - D.h.w. functioning mode                              |   |

service centrale - instalatii - autorizatii ISCIR

**Hydraulic circuit.**

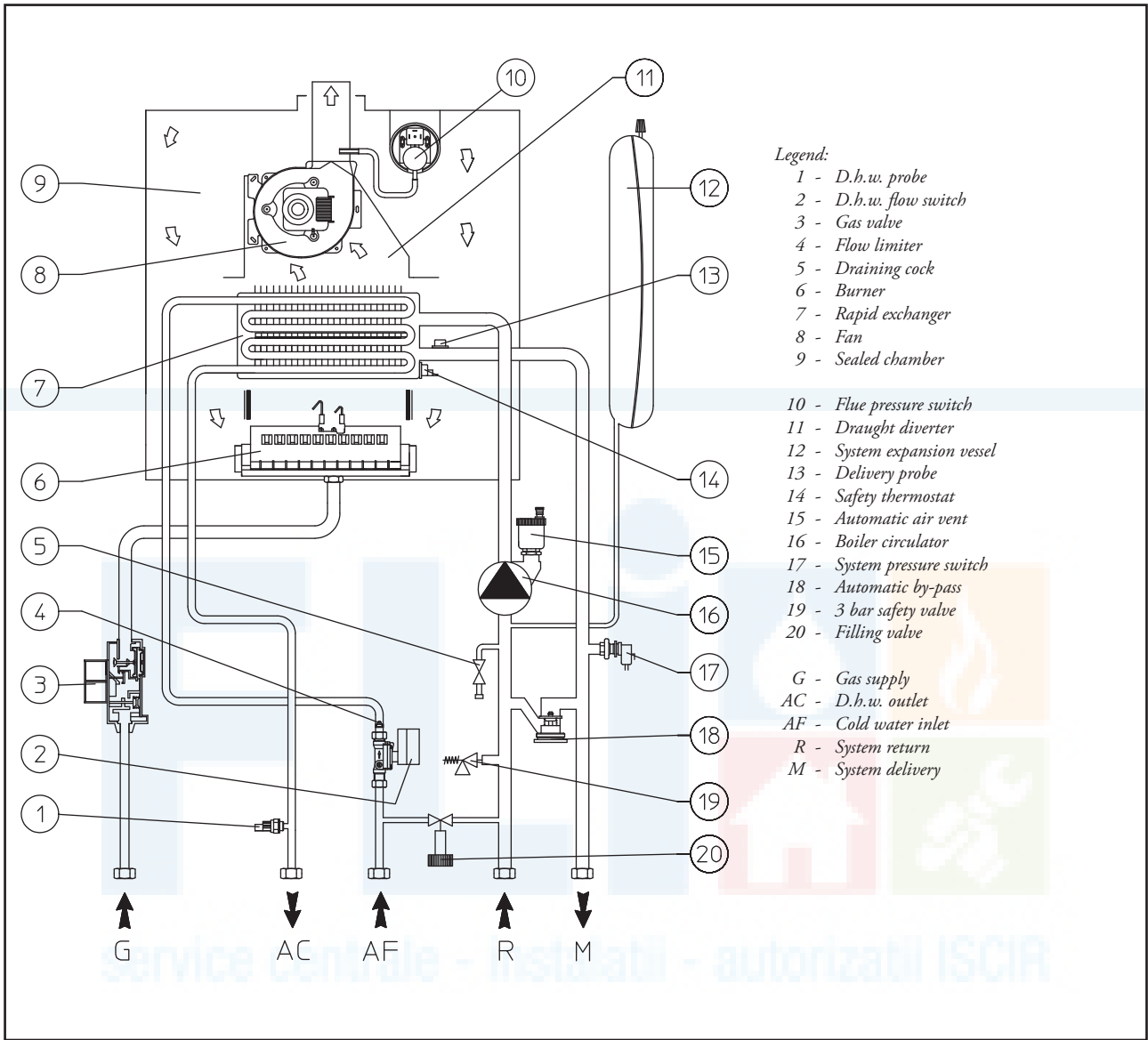

Hot water for central heating and domestic use is produced by two separate circuits that work as required.

**Primary circuit (Boiler Circuit).**

The central heating circuit, with relevant control and safety devices, is operated **every time a central heating request is made.**

**Operation.**

The heat contained in the fumes produced by combustion is absorbed by the copper blades of the water-gas exchanger (7) which, in turn, transfers it to the water circulating inside thanks to the boiler circulator (16).

The hot water is then transferred directly into the central heat-

ing system through the delivery (M) and return (R) pipes.

**Boiler circulator (1).**

The pump works on the primary circuit return and is located on the brass manifold assembly.

It is connected to the enbloc and primary exchanger by means of threaded fittings.

The automatic valve vent is housed on the body (2).

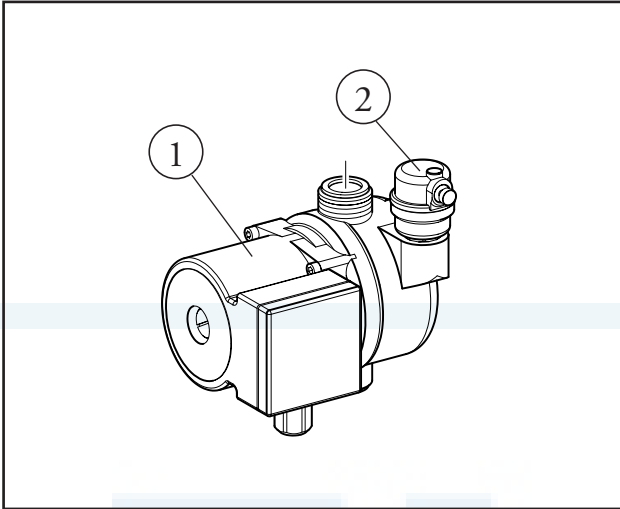

**Head flow rate graph.**

The available head the appliance is able to guarantee to the system in the central heating mode depends on the flow rate which is shown in the following graph where we can see the characteristic curve with the pump working at second and top speed.

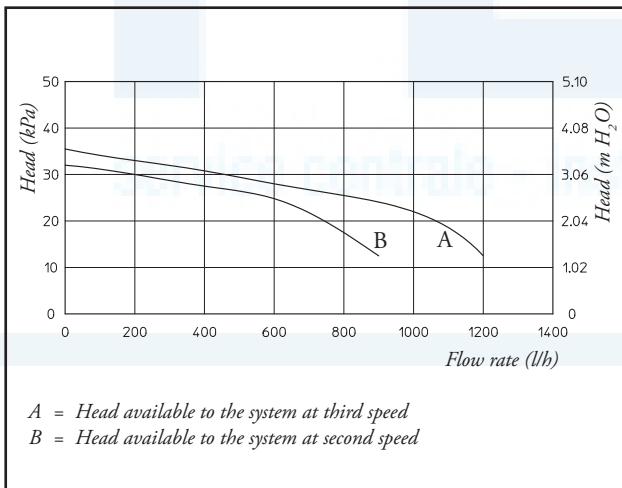

**Primary exchanger.**

This is a water-gas bithermal type blade exchanger with pipes and fins in copper for the production of hot water for central heating and domestic use.

(until serial number 3078554) number of fins = 79.

(from serial number 3078555) number of fins = 86.

It therefore works directly on both circuits to which it is connected by pipes with threaded fittings (3) with a flat gasket seal (4).

The 6 oval pipes it consists of, inside which flows the water of the central heating circuit, contain an equal number of “cross-shaped” pipes for the direct transit of domestic hot water (see illustration below).

These pipes are plumbed in parallel in groups of three on the central heating circuit and in series on the d.h.w. circuit.

The overheating safety thermostat (2) is fixed on the side of the exchanger exit with a fork (1).

The relevant NTC delivery probe is screwed into place on the central heating delivery pipe (5).

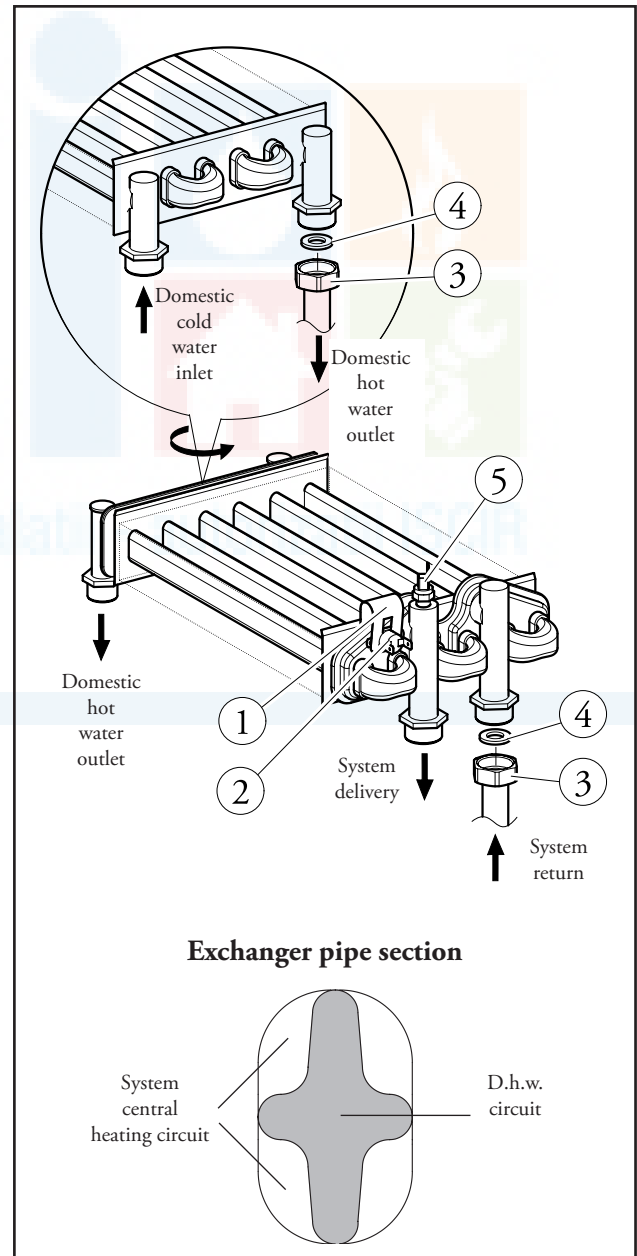

## Safety devices and controls.

### Automatic system by-pass (4).

This device ensures circulation in the central heating circuit even when this is prevented by the system's high resistance. It works between the delivery and return of the central heating circuit and is accessible after having unscrewed the cap (5) on the brass manifold's hook (1).

### System water pressure switch (7).

This is an absolute pressure switch that reads the pressure inside the central heating circuit.

It is housed in the manifold (1) and coupled to a microswitch that prevents the boiler working when the pressure measured is below 0.3 bar.

This prevents the bithermal exchanger from overheating.

### Filling valve (3).

This valve is between the boiler circuit and the domestic cold water inlet and permits pressurisation of the central heating system.

It is located underneath the brass manifold (1) to which it is screwed.

### 3-bar safety valve (2).

This valve prevents the safety pressure being exceeded in the circuit (3 bar).

It is on the front of the manifold (1), secured to it on the side with an Allen screw.

When this valve triggers, water exits from the boiler return pipe.

### Automatic air vent (8).

It automatically expels any gaseous substances from the circuit.

It is mounted on the pump's delivery side.

### Expansion vessel (9).

It compensates for variations in volume as a result of heating the water which also limits pressure variations.

It has a 6-litre capacity (3.95 useful litres) and a pre-load pressure of 1.0 bar.

It is located on the right of the boiler alongside the sealed chamber and is connected to the return manifold (1) by a copper pipe (6) with threaded fittings.

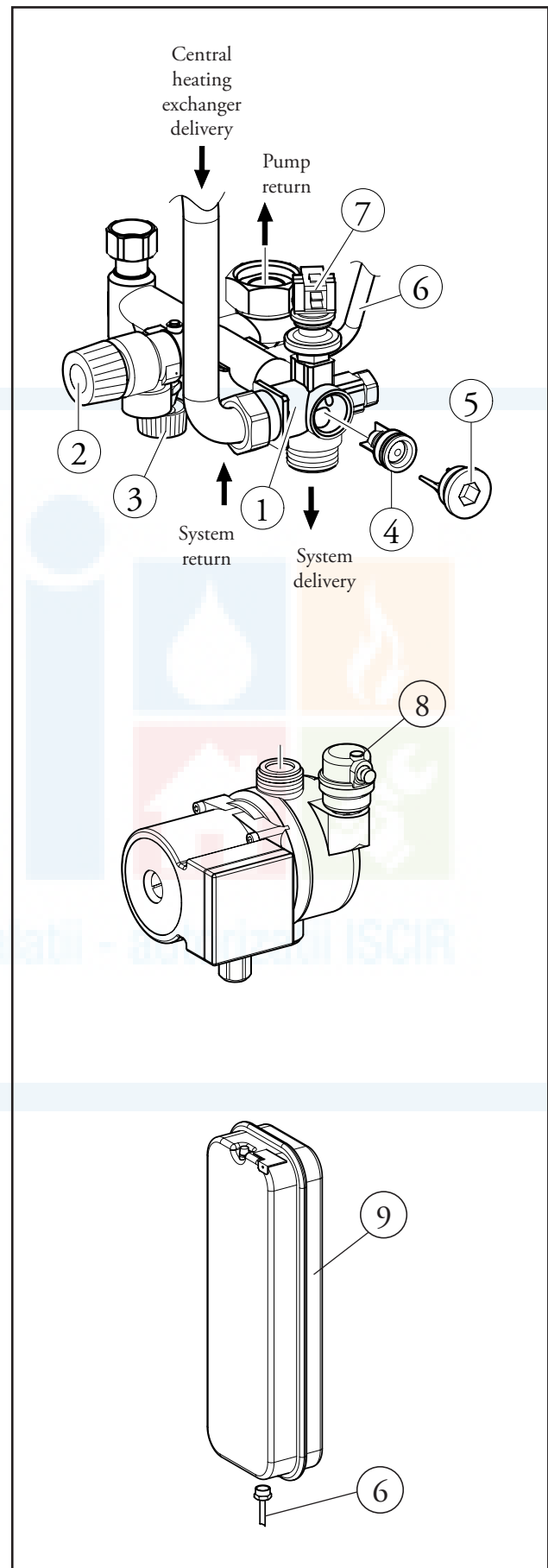



**Secondary circuit (D.h.w. circuit).**

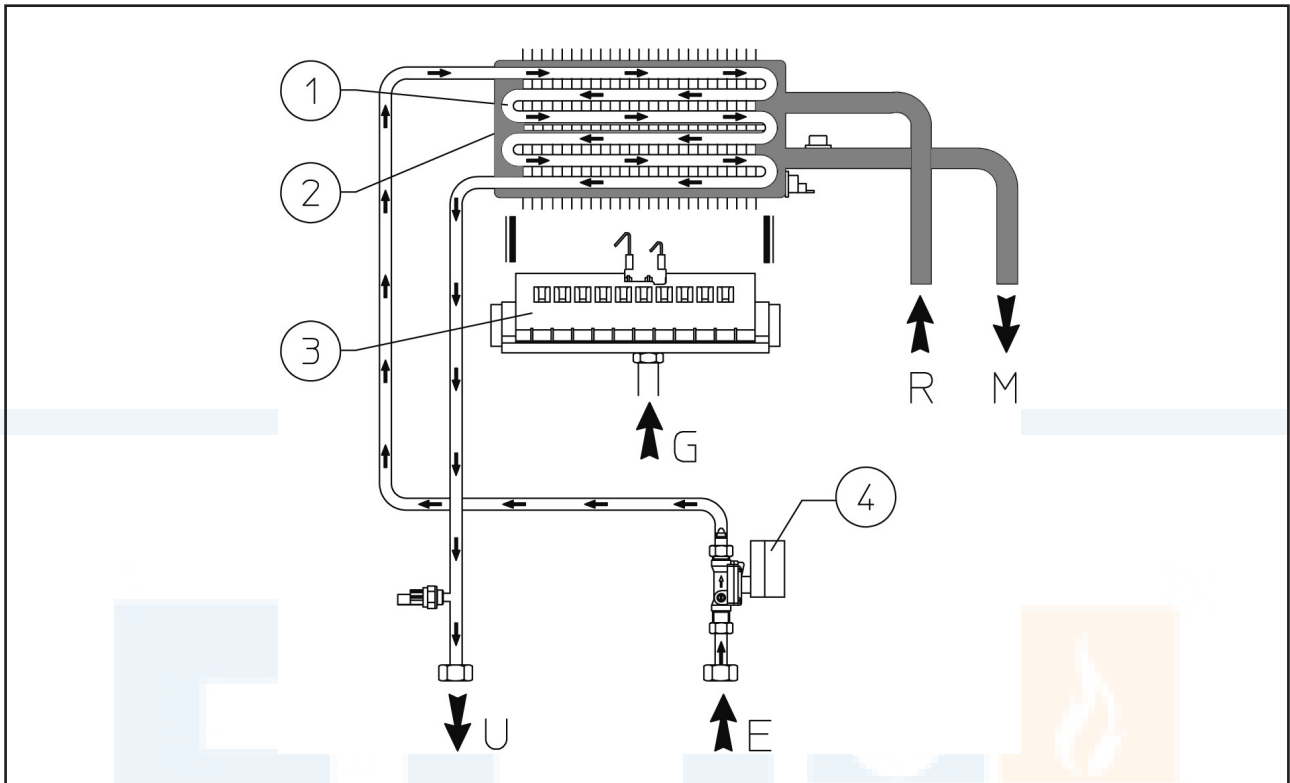

**Operation.**

When domestic hot water is drawn, cold water flows inside the flow switch (4) which closes the electrical contact coupled to it (see the electrical circuit).

As a result, the adjustment circuit starts the d.h.w. priority phase that ignites the burner (3) and, if there is an ongoing central heating request, switches the boiler circulator off.

In this way, the heat in the fumes produced by combustion is absorbed by the copper blades of the bithermal exchanger (2) and transferred to the heating circuit water which, in turn, transfers it to the domestic water circuit flowing through the “cross-shaped” hot water circuit pipes (1).

**D.h.w. flow switch.**

Whenever hot water is drawn at a rate of at least 1.5 l/min and with a dynamic pressure of 0.3 bar, the flow switch (2) enables the boiler to operate in the d.h.w. mode.

This is done by means of a magnet that, by lifting when hit by the flow of cold water, moves near to an electrical contact (reed relay) causing it to move thanks to the effect of the magnet.

When the contact closes, which is located outside the pipe through which the water flows, it enables the modulation board to start the domestic hot water priority operating mode.

It consists of two blocks (one in brass and one in plastic) that are coupled together and locked with a pin (3).

An 8.0 l/min (2 bar) flow limiter (1) is installed at the flow switch exit.

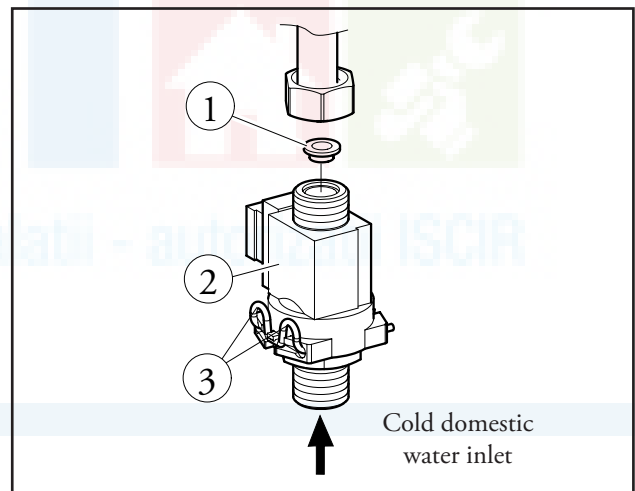

**Bithermal exchanger**

(see the central heating circuit).

*Note: to ensure long life and have an exchanger that is always efficient, we recommend installing the “polyphosphates dispenser kit” if the water is likely to lead to scale forming. For example, this kit is recommended when the hardness of the water exceeds 25 French degrees.*

**Gas circuit.**

The circuit consists of an atmospheric burner and a modulating gas valve for gas combustion and flow adjustment respectively.

**Operation.**

When the main coils are energised (3) both the inner valve shutters open allowing gas to flow towards the burner.

The flow rate/outlet pressure is set by means of the gas valve stabiliser and the modulation coil (1).

By mean of the burner nozzles (7) fuel is injected into the Venturi tubes (*ramps*) inside which the air-gas mixture is obtained that is ignited by the spark from the ignition electrode (5).

**Modulating gas valve.**

The gas valve (SIT 845) features two main coils (3) and a modulation coil (1) controlled by the integrated board.

The maximum and minimum outlet pressure can be set with this valve (*see gas settings*).

**Main electric coils (3).**

They are two ON-OFF type coils supplied (230 Vac) by the integrated board when the burner has to be ignited.

They are electrically connected in parallel and supplied by mains power through a special connector (2).

**Modulation coil (1).**

This is a low voltage coil controlled by the integrated board. It controls the gas valve stabiliser and permits changing of the outlet pressure in a way proportionate to the DC running through it.

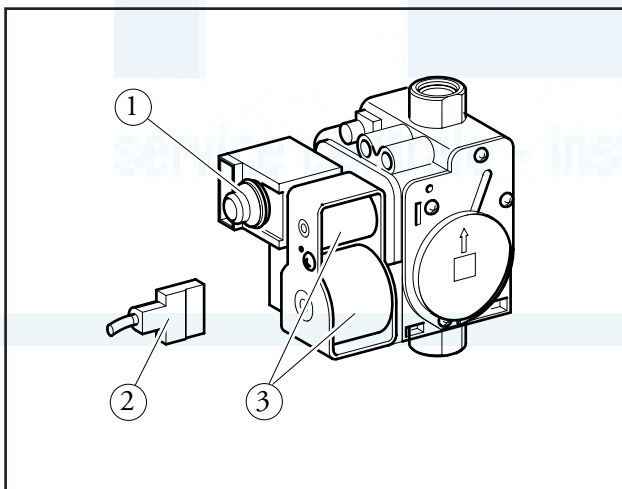

**Burner.**

The burner consists of 12 horizontal Venturi tubes (6) inside which the gas is injected by an equal number of nozzles (7) mounted on the specific manifold (8) and whose diameter varies according to the type of gas used (*see technical data*).

Ignition occurs by means of an integrated p.c.b. that controls the ignition (5) and detection (4) electrodes.

**Ignition electrode (5).**

This is controlled by the integrated board that produces an electrical charge between its end and the burner surface which is responsible for igniting the air-gas mix.

This electrode is at the front of the burner in line with the centre ramp.

**Detection electrode (4).**

This is controlled by the integrated board and detects burner ignition.

It is positioned at the front of the burner on the same ramp as the ignition electrode.

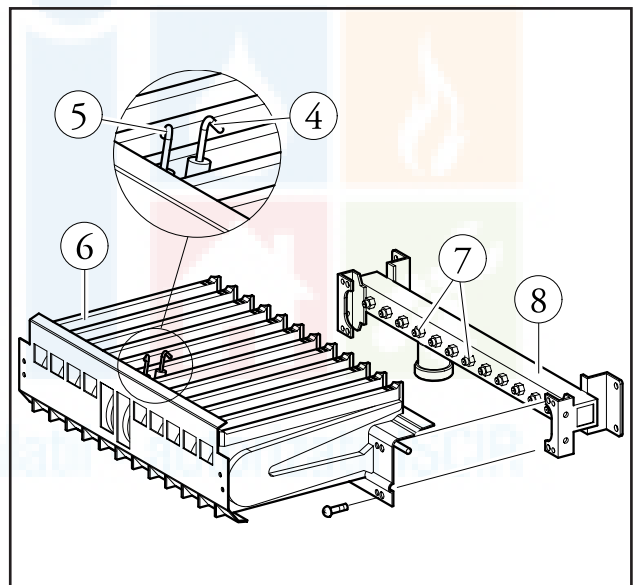

**Gas settings.**

Maximum and minimum gas pressure settings are done by means of the gas valve, respecting the values shown in the tables relating to each appliance for the relevant type of gas (see technical data).

The features of this appliance are such as to make it possible to differ minimum pressure settings during operation in both the central heating and domestic hot water modes.

The minimum gas pressure setting on the gas valve does in fact correspond to the minimum pressure in the d.h.w. phase (7.0 kW = 6,000 kcal/h) while, with regard to heating, the minimum pressure (9.3 kW = 8,000 kcal/h) can be adjusted by means of the “Minimum central heating power” parameter programmable on the integrated printed control board (see

*integrated board programming*).

A differential pressure gauge is used for reading the pressure: its positive pressure point is connected to the gas valve (4) outlet and its negative pressure point is connected to the positive pressure point on the flange with holes located at the top of the sealed chamber (see figure).

**Gas valve SIT 845.**

**Setting maximum pressure.**

Draw some domestic hot water after having put its temperature selector on maximum.

Turn the brass nut (3) clockwise to increase pressure and in the opposite direction to reduce it.

**Setting minimum pressure.**

*(to be done after setting maximum pressure).*

After turning power off to the modulation coil, turn the screw (2) clockwise to increase pressure to the burner and in the opposite direction to reduce it.

**Converting gas type.**

Adaptation to a type of gas different to the standard one the boilers are intended for can be done by using the special kits (natural gas or LPG).

Conversion consists in replacing the burner nozzles and modifying the “P1” parameter programmable on the integrated p.c.b. (see integrated board programming).

Maximum and minimum d.h.w. pressures are then set on the gas valve in the way described above.

Maximum and minimum power in the central heating mode can be set by means of parameters (see integrated board operation).

**Burner ignition pressure is not set** because the type of board operation **does not require this type of setting** (see integrated board operation).

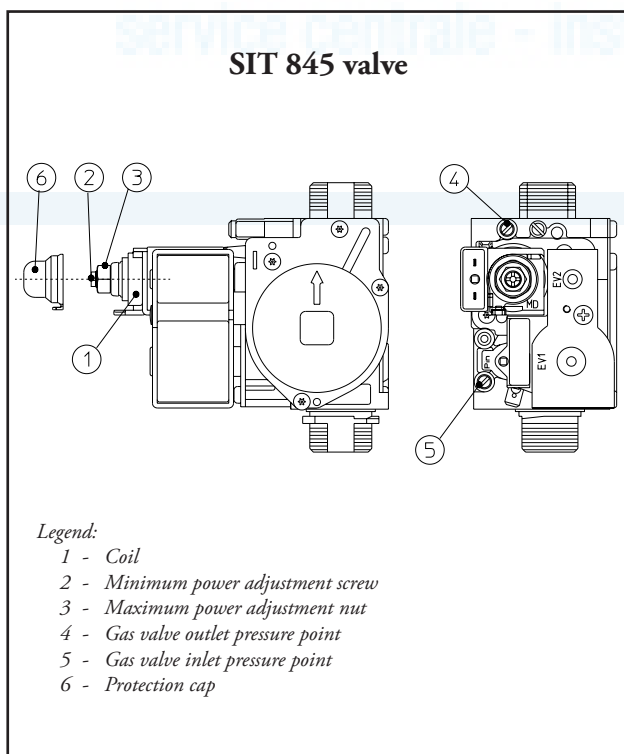
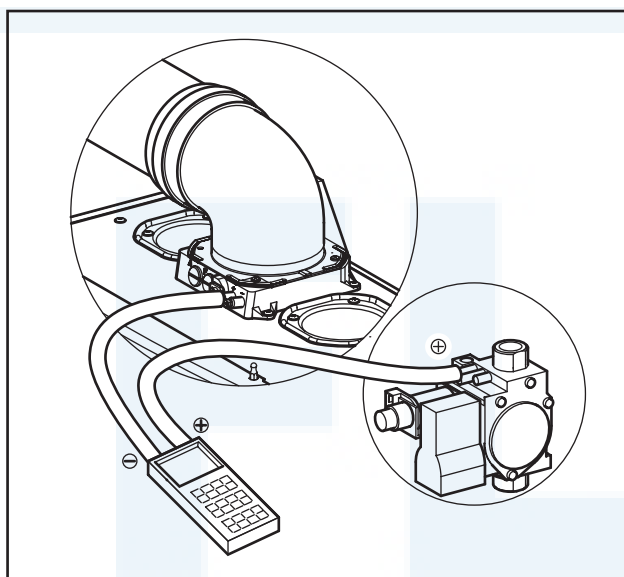

**Flue circuit.**

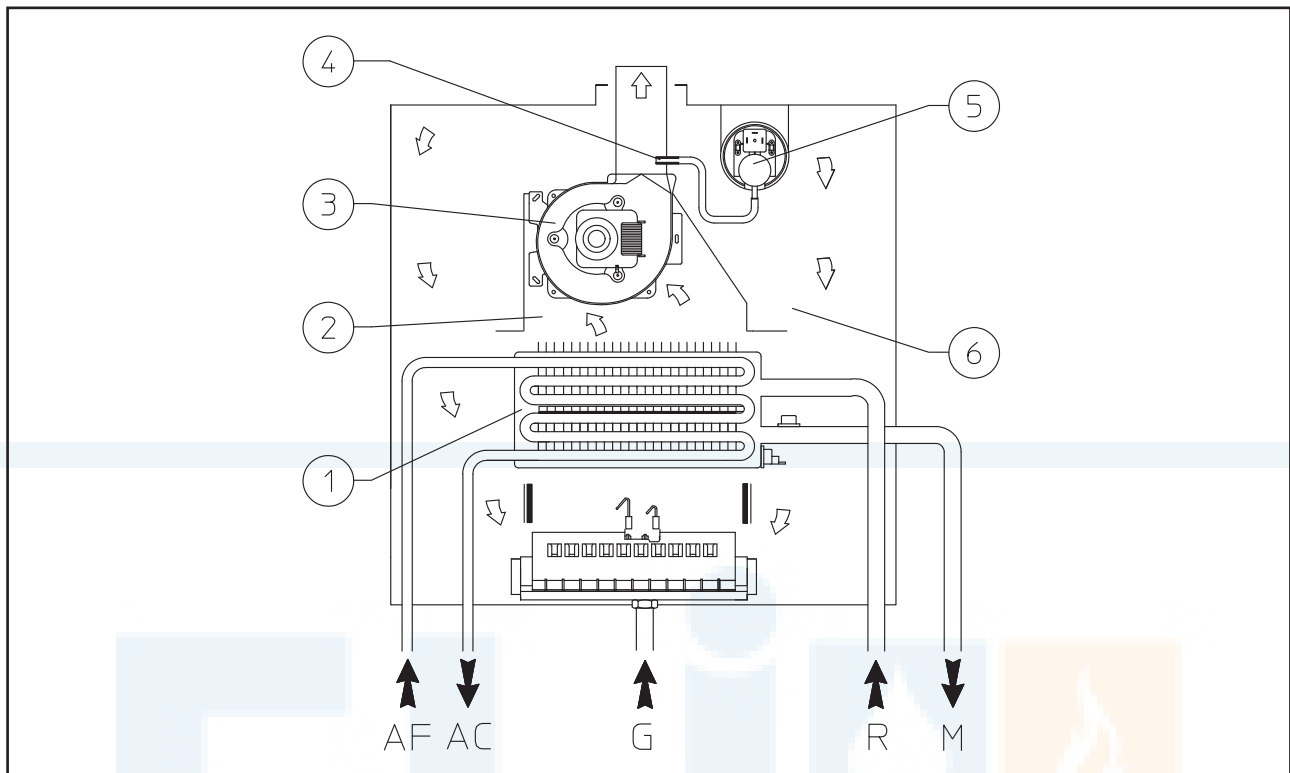

**Operation.**

The products of combustion, after hitting the water-gas exchanger (1) are conveyed to a hood (2) on top of which the fumes extractor (3) is fitted (*fan*).

Fan operation ensures the forced expulsion of the fumes and, at the same time, creates a vacuum in the sealed chamber (6) so the combustion air can be aspirated from outside.

Correct fume extraction is controlled by a differential fumes pressure switch (5); when it trips it either enables or prevents burner ignition.

**Air/fumes testing holes (7-8).**

On the top of the outside of the sealed chamber are two holes with screw closing. They are accessible from the front and are used to sample combustion air (7) and fumes (8).

**Signal pressure points, flue pressure switch (9-10).**

On the top of the outside of the sealed chamber are two pressure points with screw closing. By means of these points the signal at the ends of the flue pressure switch (5) can be measured.

*(until serial number 3078554)*

The negative pressure point (9) is coupled to a Y-shaped pipe (11) that, in turn, is connected to the negative pressure point of the flue pressure switch (5) **and to the pressure point at the outlet of the Venturi tube fitted at the end of the fan exhaust.**

The positive pressure point (10) is connected directly to the inside of the sealed chamber.

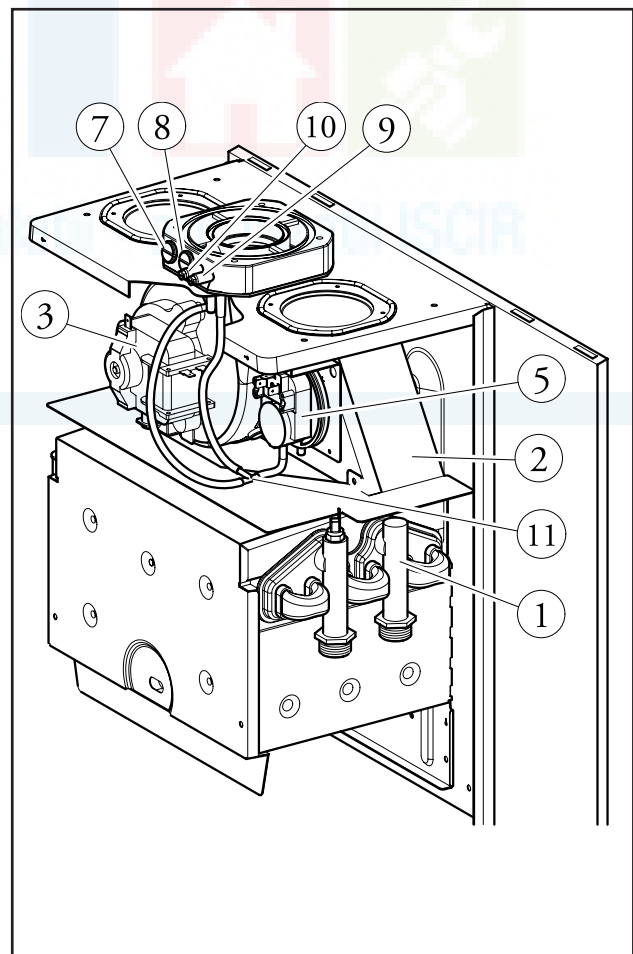

*(from serial number 3078555)*

The negative pressure point (9) is connected to a Y-shaped pipe (11) which, in turn, is connected to the negative pressure point of the flue pressure switch (5) **and to the pressure point (4) on the fan.**

The positive pressure point (10) is connected directly to the inside of the sealed chamber.

**Flue pressure switch (5).**

*(until serial number 3078554)*

It is located at the top, inside the sealed chamber and, by means of the relative points, measures the difference in pressure **between the outlet of a Venturi tube fitted on the fan exhaust (negative signal) and the inside of the sealed chamber itself (positive signal).**

The signal measured by the pressure switch varies according to the length of the intake/exhaust ends and can be measured by the relative pressure points located at the top of the sealed chamber (9-10).

When the switch trips it causes a contact (S6) to close which controls the integrated circuit, enabling or preventing burner ignition.

Flue pressure switch triggering pressures	ON Pa (mm H <sub>2</sub> O)	OFF Pa (mm H <sub>2</sub> O)
EOLO Star 23 kW	150 (15.3)	130 (13.26)

*(from serial number 3078555)*

It is located at the top, inside the sealed chamber and, by means of the relative points, measures the difference in pressure **between the fan output (negative signal) and the inside of the sealed chamber itself (positive signal).**

The signal measured by the pressure switch varies according to the length of the aspiration/exhaust terminals and can be measured by the relative pressure points located at the top of the sealed chamber (9-10).

When this switch trips it causes a contact (S6) to close that acts on the integrated board, enabling or preventing burner ignition.

Flue pressure switch triggering pressures	ON Pa (mm H <sub>2</sub> O)	OFF Pa (mm H <sub>2</sub> O)
EOLO Star 23 kW	44 (4.5)	36 (3.7)

**Fan (3).**

The extractor works downstream from the combustion chamber and is secured vertically to the top of the hood (2) from which it extracts the fumes, conveying them to the exhaust pipes to which the boiler is connected. At the same time it guarantees the flow of air inside the sealed chamber.

It is controlled by the integrated board and its operation basically coincides with that of the burner.

*(until serial number 3078554)*

**A Venturi tube is fitted inside its exhaust outlet and the flue pressure switch's (5) negative signal is measured at its outlet.**





**Extraction and exhaust systems.**

The EOLO Star 23 kW is designed for being connected to the special intake/exhaust coupling pipes.

*(until serial number 2972938)* It is possible to use the concentric flue pipes (Ø60/100 and Ø80/125), only.

*(from serial number 2972939)* over than the concentric flue pipes (Ø60/100 and Ø80/125) it is also possible to use the Ø80/80 coupling type separator kits.

These kits are able to split the air inlet and discharge of the exhaust flues.

**Sealed chamber, fan-assisted configuration (type C).**

**Exhaust.**

Connection to the fumes exhaust pipes is through a flange (1) or a flanged curve to fix to the fitting (4) at the top of the sealed chamber, placing a shaped seal in between (6).

The flange differs according to whether the system is used split or concentric.

In the first case, the passage for the intake of combustion air (5) is closed while in the second case it is used.

To ensure correct operation of the boiler it is necessary to put a diaphragm (7) on the exhaust fitting (4), between it and the flange used (1).

There are different diameter diaphragms, mounted according to the type of pipe and its length *(see boiler instruction booklet)*.

**Intake.**

Using the split system, connection to the intake pipes is done in exactly the same way as for the exhaust pipes, connecting to one of the two 80 mm Ø holes (2) at the top of the sealed chamber.

The unused hole is closed with one of the plastic caps (3) supplied with the boiler.

If coaxial pipes are used, the intake of combustion air is done exploiting the concentric hole, outside the exhaust fitting (5).

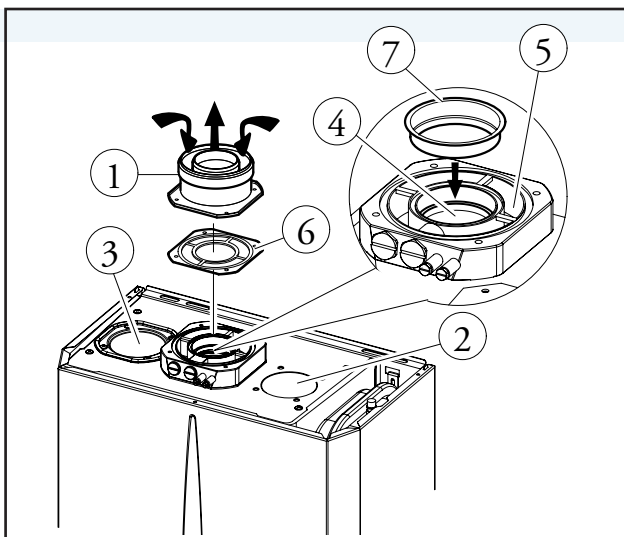

**Intake and Exhaust Kits.**

The kits and their accessories permit use of four concentric systems and two split systems.

As regards pressure losses relating to each accessory, the various possible combinations and the use of the diaphragms depending on the length of the pipes used, **follow the instructions given for the intake and exhaust terminals** *(see the boiler instruction booklet)*.

The coupling of the accessories *(bends, extensions and terminals)* is the fitted type while sealing is guaranteed by silicone lip seals.

**Coupling type horizontal concentric kit Ø 60/100.**

The exhaust pipe (60 mm Ø) is fitted inside the aspiration pipe (100 mm Ø).

Connection to the boiler is done using a 90° bend (2) that can be positioned in any direction and which, by means of the necessary extensions, is connected to the specific aspiration and exhaust terminal (3).

The maximum overall permitted length beyond the first bend (2) is **3 straight horizontal metres**.

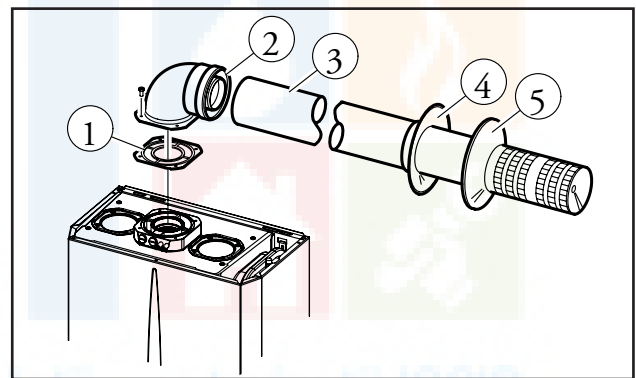

**Coupling type horizontal concentric kit Ø 80/125.**

The exhaust pipe (80 mm Ø) is fitted inside the aspiration pipe (125 mm Ø).

Connection to the boiler is done using a 90° 60/100 Ø bend (2) that can be positioned in any direction and which, by means of the 60/100-80/125 adapter (3) and necessary extensions, is connected to the specific aspiration and exhaust terminal (4).

The maximum overall permitted length beyond the first bend (2) is **7.3 straight horizontal metres**.

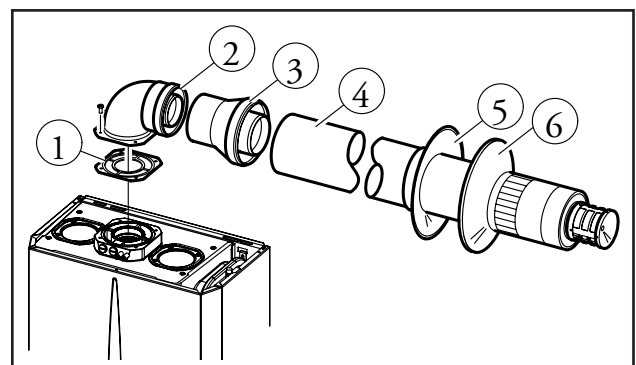

**Coupling type vertical concentric kit Ø 80/125.**

The exhaust pipe (80 mm Ø) is fitted inside the aspiration pipe (125 mm Ø).

Connection to the boiler is done using a flange (2) that, by means of the 60/100-80/125 adapter (3) and necessary extensions, is connected to the specific aspiration and exhaust terminal 80/125 with aluminium tile (6).

The maximum overall permitted length is **12.2 straight vertical metres**.

**Coupling type vertical concentric kit Ø 60/100.**

The exhaust pipe (60 mm Ø) is fitted inside the aspiration pipe (100 mm Ø).

Connection to the boiler is done using a flange (2) that, by means of the necessary extensions, is connected to the specific aspiration and exhaust terminal 60 /100 with aluminium tile.

The maximum overall permitted length is **4.7 straight vertical metres**.

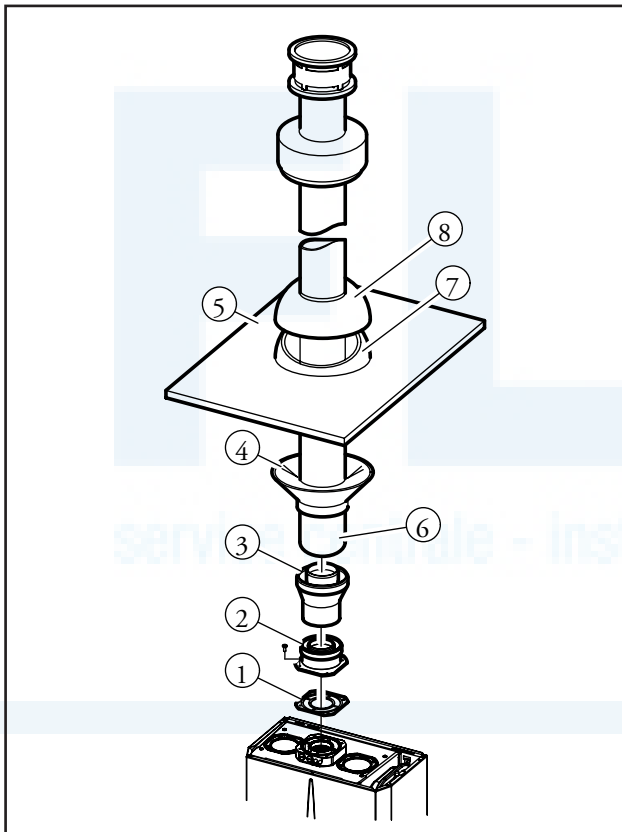

**80/80 Ø coupling type separator kit.**

Both pipes are 80 mm in diameter.

Connections to the boiler are done using the two specific flanges that allow discharge (4) from the centre fitting and aspiration (3) from one of the two side holes.

The maximum permitted length (*aspiration + exhaust*) is **33 straight horizontal metres and 41 straight vertical metres**.

To avoid condensate problems, the exhaust pipe is limited to a **maximum of 5 metres**.

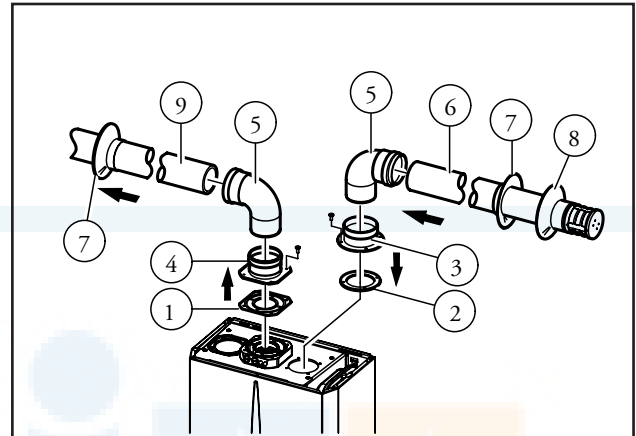

**80/80 Ø insulated coupling type separator kit.**

Both pipes are 80 mm in diameter.

Connections to the boiler are done using the two specific flanges that allow discharge (4) from the centre fitting and aspiration (3) from one of the two side holes.

Insulation is by way of the seals (6) which create an air gap with the external concentric 125 mm Ø pipe.

The maximum permitted length is **33 straight metres** (*aspiration + exhaust*).

To avoid condensate problems, the exhaust pipe is limited to a **maximum of 12 metres**.

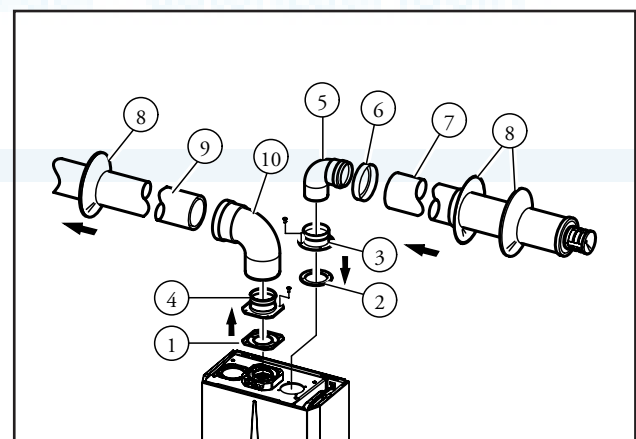

**Electrical circuit.**

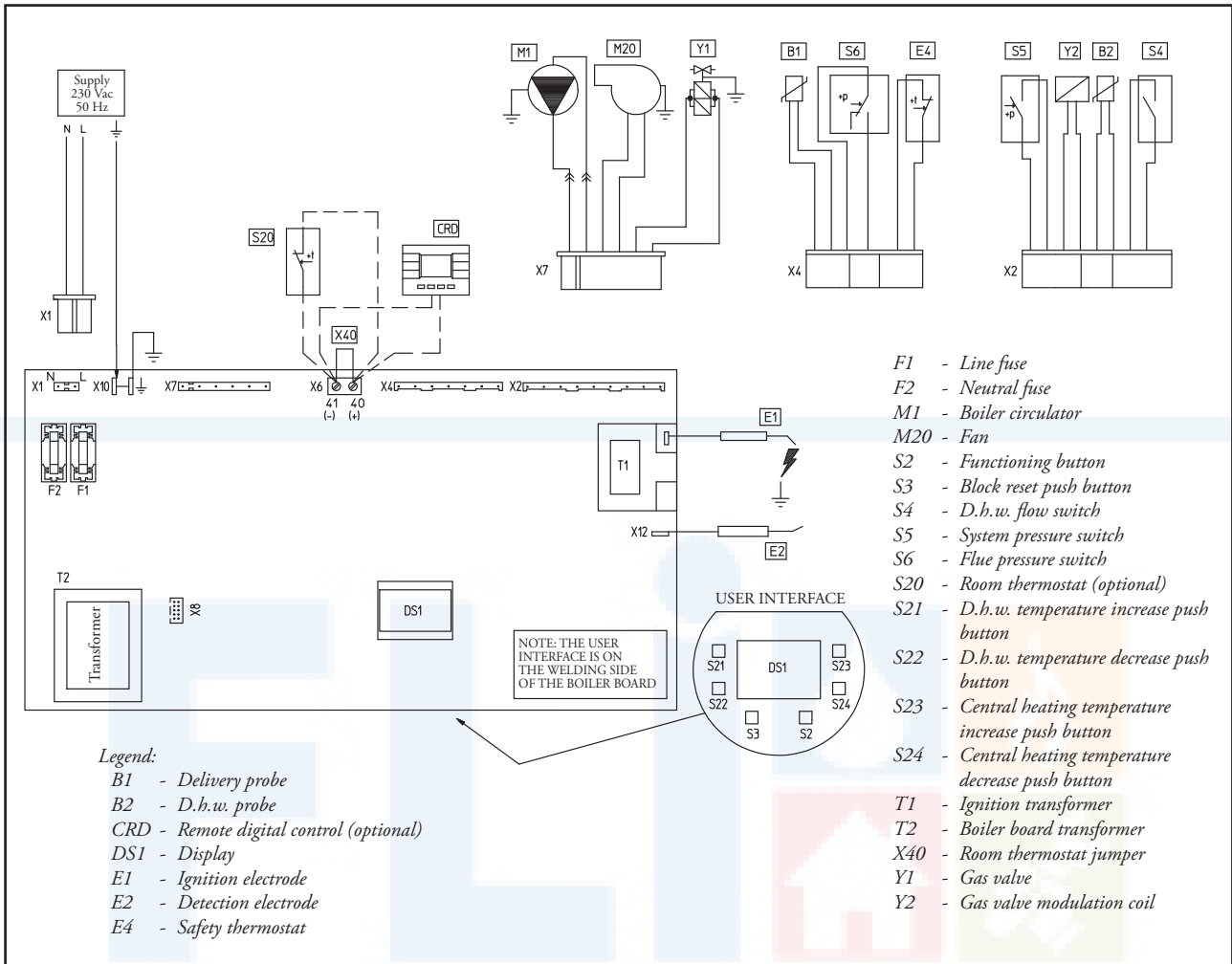

The electrical circuit of the EOLO Star 23 kW boiler is managed 100% by a microprocessor driven p.c.b. which controls the boiler's functions.  
Some of the control and safety devices operate at mains voltage (230 Vac) while others at low voltage.

**230 V AC circuit.**

**Safety devices and controls.**

<b>Detection electrode (E2)</b>	It detects burner ignition, being hit by its flame. It's connected to the integrated board.	
<b>Line fuse (F1)</b>	They interrupt power to the circuit when power input is over 3.15 A. They are mounted on the integrated board.	Fuse 3.15 AF 250 V
<b>Neutral fuse (F2)</b>		





**Loads.**

<b>Ignition electrode (E1)</b>	It is controlled by the integrated board that provokes a spark between its end and the burner surface that ignites the air/gas mix.
<b>Boiler circulator (M1)</b>	It is powered by the integrated board when there's either a central heating or antifreeze request. It permits circulation in the primary circuit.
<b>Integrated board</b>	This board is always powered regardless of the position of the functioning button (S2) ( <i>see integrated board operation</i> ).
<b>Gas valve (Y1) (main coils)</b>	It is powered at mains voltage by the integrated board when it is necessary to ignite the burner. It permits the flow of gas to the burner.
<b>Fan (M20)</b>	It ensures the flow of air inside the sealed chamber and the exit of fumes produced by combustion. It is powered by the integrated board.

**Low voltage circuit.**

**Safety devices and controls.**

<b>Remote digital control (CRD) (optional)</b>	This device is to control the appliance remotely ( <i>SUMMER / WINTER selection, setting and indicating temperatures, displaying alarms, resetting, etc.</i> ) and acts as a weekly timer/room thermostat. If the CRD is installed the X40 jumper must be removed.	<b>See Remote Digital Control Operation (CRD)</b>
<b>D.h.w. flow switch (S4)</b>	This switch acts on the integrated board after some domestic water has been drawn, causing the boiler to work in the d.h.w. mode. When idle it enable operation in the central heating mode.	Interrupted contact
<b>System pressure switch (S5)</b>	When pressure in the boiler circuit is below 0.3 bar the burner switches off.	Interrupted contact
<b>Flue pressure switch (S6)</b>	This acts on the integrated board and enables burner operation when the fumes are expelled correctly. When closed and the fan is off, it does not enable the start of the ignition cycle.	Changing contact

<p><b>Reset push button (S3)</b></p>	<p>It unblocks the boiler following either the ignition failure or over-temperature safety device triggering; it can be used to activate the chimney sweep function. If pressed together with the functioning button (S2) it lets you access the boiler parameter settings.</p>	<p>Push button</p>
<p><b>Functioning button (S2)</b></p>	<p>The possible functioning selections are:   = Circuit powered, the antifreeze and antiblock functions are still active, the various post circulation and post ventilation functions are completed.   = Boiler operation in SUMMER.   = Boiler operation in WINTER.</p>	<p>Push button</p>
<p><b>Delivery probe (B1)</b></p>	<p>It lets the integrated board measure the temperature of the delivery water in the primary circuit. If it breaks the burner stops working whether in the central heating or d.h.w. mode. It is located on the central heating delivery pipe of the bithermal exchanger.</p>	<p>NTC probe 10 kohm 25 °C</p>
<p><b>D.h.w. probe (B2)</b></p>	<p>It lets the integrated board measure the outlet temperature of the domestic hot water. If it breaks, functioning in the d.h.w. mode is stopped but functioning in the central heating mode is allowed. It is inserted in the d.h.w outlet pipe connected to the bithermal exchanger.</p>	<p>NTC probe 10 kohm 25 °C</p>
<p><b>Room thermostat (S20) (external optional)</b></p>	<p>It enables operation in the central heating mode when room temperature is below that required. If this room thermostat is installed the X40 jumper must be removed.</p>	<p>Interrupted contact</p>
<p><b>Safety thermostat (E4)</b></p>	<p>The burner switches off when the safety temperature is exceeded (105 °C). It is located at the main exchanger outlet.</p>	<p>Clicson thermostat with normally closed contact</p>

**Loads.**

<p><b>Gas valve modulation coil (Y2)</b></p>	<p>It is powered by the integrated board with a variable continuous current. It permits varying of the gas pressure to the burner.</p>
--	--

**Electrical circuit.**

**Central heating phase.**

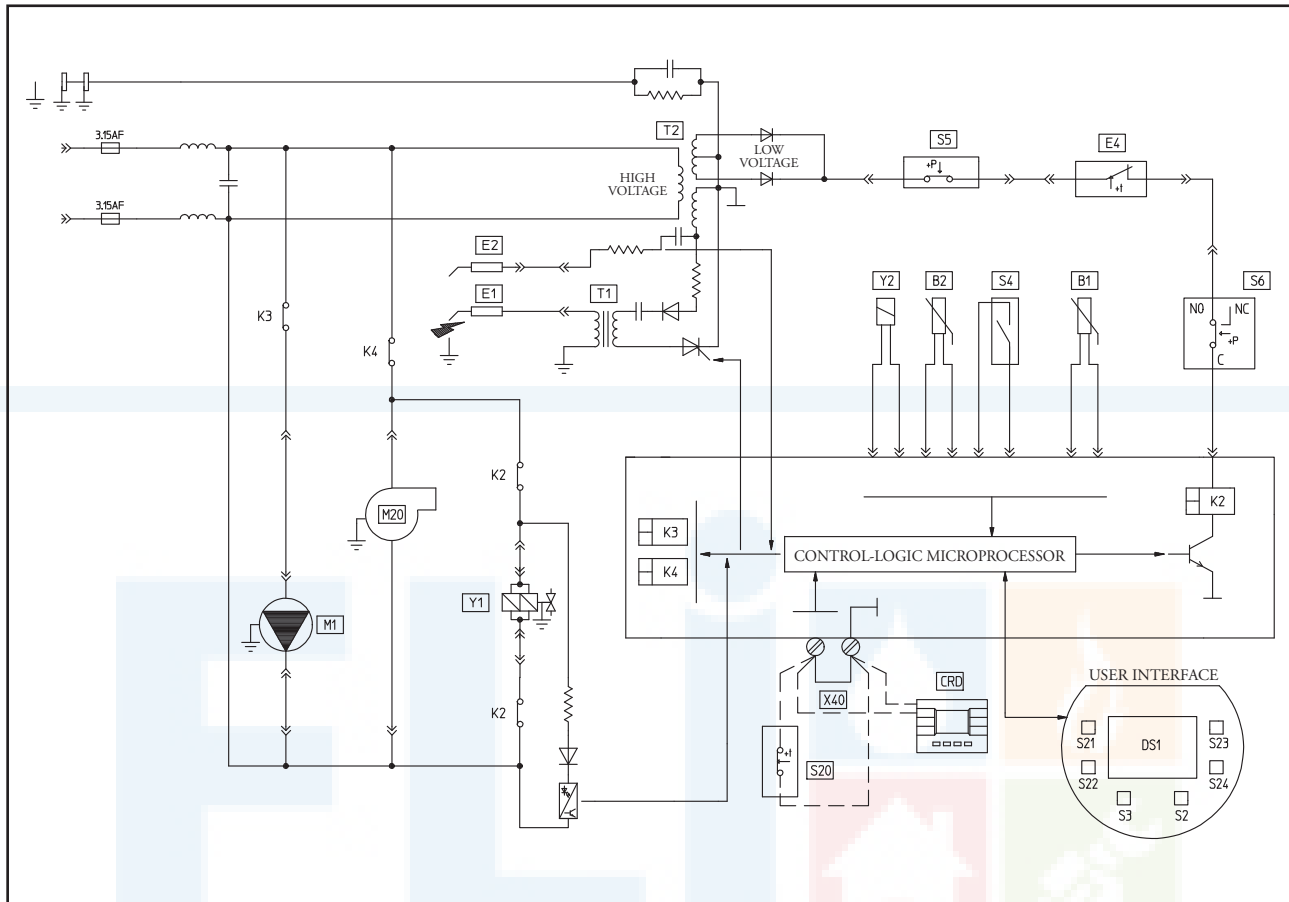

**Working with the room thermostat.**

By selecting the  (Winter) functioning mode with the (S2) push button the boiler is enabled to work in the central heating mode.

When the room thermostat (S20) closes the integrated board powers the boiler circulator (M1) by means of relay K3.

In the meantime, if the flue pressure switch (S6) contact is idle “NC”, the adjustment circuit powers the fan (M20) by means of relay K4.

If the following conditions occur: the system pressure switch contact (S5) is closed (*pressure in the primary circuit higher than the minimum value*), the safety thermostat (E4) is enabled, the flue pressure switch contact (S6) is in “NO” position and the temperature read by the NTC delivery probe (B1) is below the value set on the boiler’s control panel, then the P.C.B. energises the request relay K2.

This operation causes the closing of the 2 contacts which starts the ignition cycle, first of all supplying the ignition electrode (E1) and then both the coils of the gas valve (Y1).

Burner ignition is detected by the integrated board by means of the ionisation electrode (E2).

**Remote digital control operation.**

By selecting the Winter functioning mode on the Remote Digital Control (CRD) panel, the boiler is enabled to work in the central heating mode.

If the conditions detected by the CRD require ignition in the central heating mode, the integrated board powers the boiler circulator (M1) via the relay K3 and the burner ignites as described above.



**Note:** With each switching off when the temperature is reached, the integrated board stops the burner working in the central heating mode for a time equal to that set with the board parameters (*see integrated board operation*).

**Electrical circuit.**

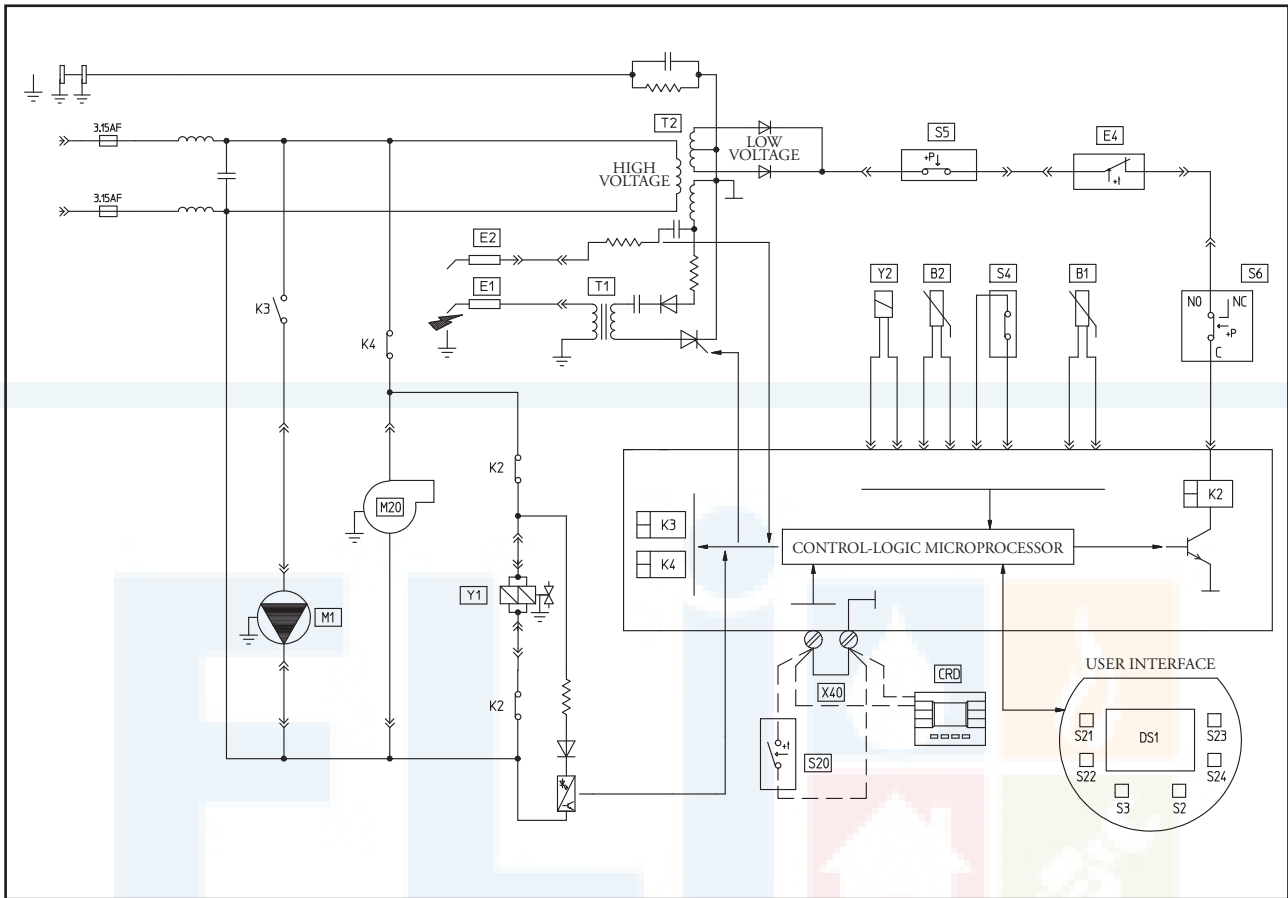
**D.h.w. phase.**



**Operation.**

By selecting the  (Summer) or  (Winter) functioning mode with the (S2) push button the boiler is enabled to work in the domestic hot water mode.

When some domestic water is drawn it causes the d.h.w. flow switch (S4) contact to close and enables operation in the d.h.w. mode.

**The boiler circulator (M1) is not started in the domestic hot water mode or is switched off if there is an ongoing central heating request upon opening of relay K3.**

If the temperature read by the NTC d.h.w. probe (B2) is below the value set on the boiler's control panel (or on the CRD if installed) and if the fumes pressure switch contact (S6) is idle "NC", the adjustment circuit powers the fan (M20) by means of relay K4.

If the contact of the system pressure switch (S5) is closed (pressure in the primary circuit higher than the minimum value) the board, being enabled by the safety thermostat (E4) and with switching of the flue pressure switch to "NO" (S6), closes the contact of the request relay K2 which causes the 2 contacts to close and the ignition cycle to start, first of all triggering the ignition electrode (E1) and then both the coils of the gas valve (Y1).

Burner ignition is detected by the integrated board by means of the ionisation electrode (E2).

**Modulation board.**

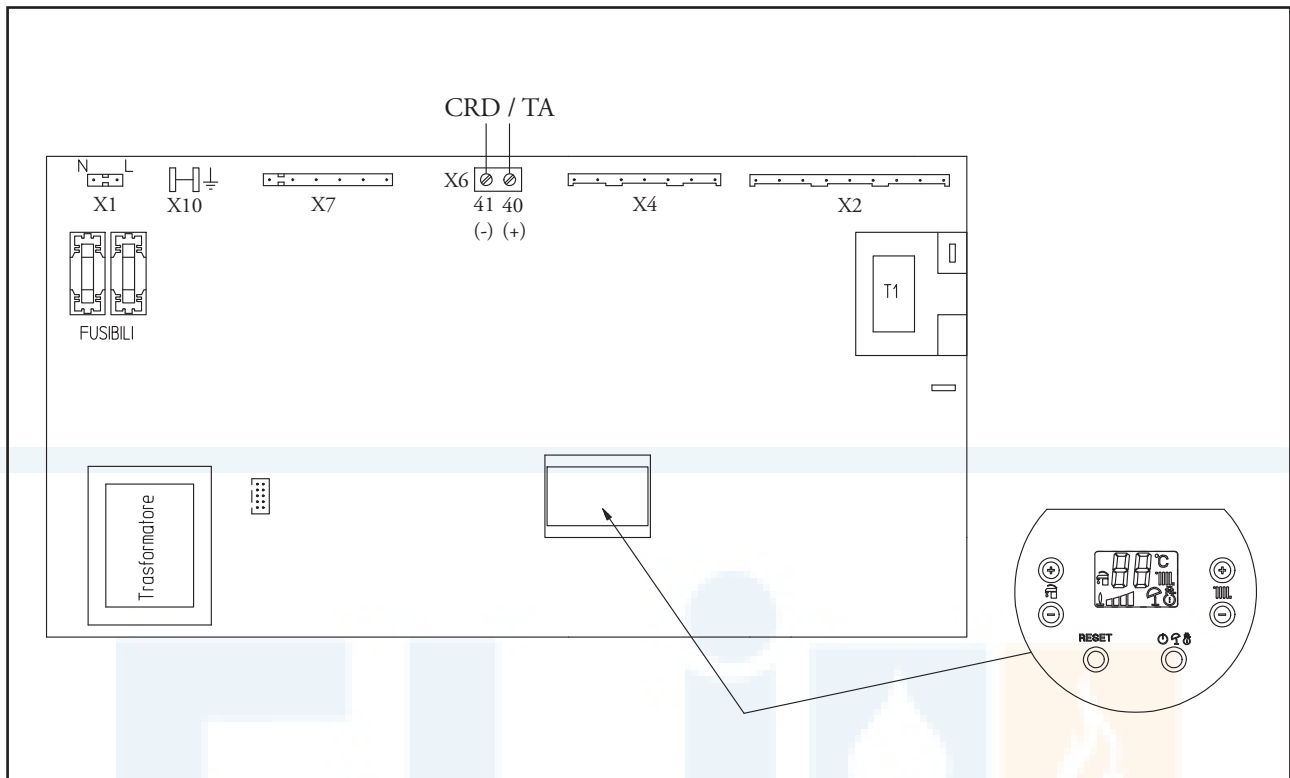

Inside the boiler's control panel is a microprocessor controlled electronic board that controls the appliance's electrical devices and sees to the linear modulation of burner power.

The appliance's functioning status is shown on a display, indicating if any of its safety devices have triggered.

**The same board is used on all models, whether they are the conventional or sealed chamber (NIKE/EOLO Star kW) types.** The different boiler functioning modes are recognised automatically by means of the appliance's wiring.

The integrated board is always powered regardless of the operating position determined by the functioning button (S2).

The board executes a periodical self-check to make sure it is working properly. During the central heating functioning mode or with the boiler in Stand-by, this function is activated every 18 hours from the last boiler check/powering. During the d.h.w. functioning mode, this self-check starts within 10 minutes from the last time water was drawn and lasts 10 seconds.

**NOTE:** the boiler stops working (together with indications) during the self-check operation.

**Operation.**

**Central heating request.**

By selecting the  (Winter) functioning mode with the (S2) push button the boiler is enabled to work in the central heating mode.

When the room thermostat (S20) closes the integrated board powers the boiler circulator (M1) by means of relay K3.

In the meantime, if the flue pressure switch (S6) contact is idle "NC", the adjustment circuit powers the fan (M20) by

means of relay K4.

If the following conditions occur: the system pressure switch contact (S5) is closed (*pressure in the primary circuit higher than the minimum value*), the safety thermostat (E4) is enabled, the flue pressure switch contact (S6) is in "NO" position and the temperature read by the NTC delivery probe (B1) is below the value set on the boiler's control panel, then the P.C.B. energises the request relay K2 which causes the 2 contacts to close which starts the ignition cycle.

During the first few seconds after the gas valve (Y1) has been powered, the current to the modulation coil (Y2) is limited to the predefined soft ignition current.

The burner will then go to the minimum set value (set in the "Minimum Central Heating Power\*" parameter), reaching the maximum set value (*if requested*) (set in the "Maximum Central Heating Power\*" parameter) in a time set in the "Central Heating Ramp Time\*" parameter.

Subsequently, the signal is varied directly proportionate to the difference between the temperature set on the boiler control panel and the temperature read by the delivery probe (B1).

When the set temperature (+5°C) is exceeded, the contact of relay K2 is opened and the burner is switched off. Re-ignition time depends on how the "Central Heating Ignitions Timer" parameter is set.

Each time the burner switches off the fan and pump keep working for another 30 seconds.

\* see Integrated board programming.

### D.h.w. request.

When some domestic water is drawn it causes the d.h.w. flow switch (S4) contact to close and enables operation in the domestic hot water mode.

**When the boiler is working in the d.h.w. mode the boiler circulator (M1) is not started or is switched off if there is an ongoing central heating request.**

For burner ignition proceed in exactly the same way as for the central heating mode.

During the first few seconds after the gas valve (Y1) has been powered, the current to the modulation coil (Y2) is limited to the predefined soft ignition current.

Once the flame is detected, the signal to the modulation coil is increased so as to reach the maximum power set on the gas valve immediately (*if requested*).

Flame modulation then occurs with reference to the difference between the temperature set on the boiler control panel and the temperature detected by the d.h.w. probe (B2).

When the temperature of 65°C is exceeded, the contact of relay K2 is opened and reclosed as soon as the temperature drops below 64 °C.

An increase in delivery temperature that goes beyond the triggering limit point (80°C) causes a proportional reduction in the modulation current in order to limit such a temperature.

If delivery temperature still reaches the switching off point (90°C limit) the burner is switched off and a post ventilation phase is carried out.

### Central heating antifreeze request.

When the temperature read by the central heating delivery probe (B1) drops below 4°C, the board enables ignition and keeps the boiler going with the burner at minimum power until a boiler temperature of 42°C is reached (*radiator antifreeze*).

### Domestic hot water antifreeze request.

If the temperature read by the d.h.w. probe (B2) drops below 8°C, the integrated board enables ignition of the boiler circulator.

If, on the other hand, the temperature read by the d.h.w. probe (B2) drops below 4°C, the board enables boiler ignition and keeps it going with the burner at minimum central heating power until the d.h.w. probe (B2) reads a temperature of 8°C after which a post circulation cycle is activated in the central heating mode that lasts 150 seconds.

The water in the primary circuit is kept below 42°C during operation because if this temperature is reached the board switches the burner off.

### “Chimneysweep” request.

Pressing the “Reset” push button (S3) for at least 10 seconds and releasing it, the board enables ignition of the boiler and keeps it working at maximum central heating power set for 15 minutes.

During this time only the limit thermostat function is observed (90°C) which is carried out by means of the central heating delivery probe (B1).

The function is indicated on the boiler display, with the (🔥) and (🏠) symbols flashing; it cannot work if there is an ongoing d.h.w. request.

It can be interrupted by cutting power to the circuit, putting the boiling in Stand-by (⏻), either carrying out a d.h.w. request or after 15 minutes.



### Inputs.

<p><b>Remote digital control (CRD)</b> <i>(optional)</i></p>	<p>It sends to the electronic board the signals about the functioning mode (<i>Stand-by / Summer / Winter</i>), the temperatures setting (<i>domestic hot water and central heating</i>) and the heating requests (<i>times, room temperature, etc.</i>).</p>	
<p><b>D.h.w. flow switch (S4)</b></p>	<p>It indicates an ongoing d.h.w. request. After domestic hot water has been drawn, it enables boiler operation in the domestic hot water mode which is given priority over the system central heating mode.</p>	<p>Closed = d.h.w. request</p>
<p><b>System pressure switch (S5)</b></p>	<p>When the pressure in the primary circuit is below 0.3 bar this switch cuts power off to the K2 relay preventing the start of the ignition cycle.</p>	<p>Open = no pressure Closed = pressure OK</p>
<p><b>Flue pressure switch (S6)</b></p>	<p>This switch enables burner ignition powering the K2 relay when the fumes are being expelled correctly. If the “NO” contact closes with the fan off, it does not enable start of the ignition cycle.</p>	<p>Changing contact</p>
<p><b>Flame detection (E2)</b></p>	<p>This signal indicates the burner flame has been detected. It allows the board to increase current to the modulation coil (Y2) after having limited it during the ignition phase. It keeps the gas valve (Y1) open.</p>	
<p><b>Delivery probe (B1)</b></p>	<p>It is a resistor that varies in an inversely proportionate way to the temperature of the primary circuit delivery water. It is also used as a limit thermostat (90°C).</p>	<p>NTC probe 10 kohm 25 °C</p>
<p><b>D.h.w. probe (B2)</b></p>	<p>It is a resistor that varies in an inversely proportionate way to the outlet temperature of the domestic hot water.</p>	<p>NTC probe 10 kohm 25 °C</p>
<p><b>Room thermostat (S20)</b> <i>(external optional)</i></p>	<p>It is a switch with free contacts that sends a (<i>low voltage</i>) signal to the board, enabling operation in the central heating mode when room temperature is below that requested.</p>	<p>Open = Central heating OFF Closed = Central heating ON</p>

### Outputs.

<p><b>Gas valve power supply (Y1)</b></p>	<p>It is a 230 V ac signal indicating that the main gas valve (Y1) coils are supplied.</p>	<p>230 Vac = coils supplied 0 Vac = coils not supplied</p>
<p><b>Ignition electrode (E1)</b></p>	<p>It is a high voltage signal (<i>higher than 16 kV</i>) that determines an electrical discharge at the end of the ignition electrode located on the burner.</p>	
<p><b>Remote digital control (CRD) (optional)</b></p>	<p>This is a (BUS) signal by means of which boiler temperature, operation in the d.h.w. or central heating mode, and triggered alarms codes can be seen on the remote control display.</p>	
<p><b>Gas valve modulation coil (Y2)</b></p>	<p>It is a d.c. signal that controls the modulation coil; the pressure of gas to the burner may be varied according to the output required.</p>	
<p><b>Pump relay (K3)</b></p>	<p>It is a unipolar relay for controlling the pump (M1) that is energised when its operation is requested.</p>	
<p><b>Request relay (K2)</b></p>	<p>This is a bipolar relay that is excited when the burner has to be ignited. By means of its contact, boiler ignition is enabled.</p>	
<p><b>Fan relay (K4)</b></p>	<p>This is a unipolar relay for controlling the fan (M20) that is excited when its operation is requested.</p>	

### Safety devices.

<p><b>Circulator antiblock device</b></p>	<p>The boiler circulator (M1) is turned on for 30 seconds after:</p> <ul style="list-style-type: none"> <li>- 24 hours of inactivity with the boiler in the SUMMER mode (☀).</li> <li>- 3 hours of inactivity with the boiler in the WINTER mode (❄).</li> </ul>	
<p><b>Electromechanical contacts block (system pressure switch, safety thermostat and flue pressure switch) (from October 2005)</b></p>	<p>If there is strong resistance of the system pressure switch, of the safety thermostat or flue pressure switch contact (<i>contact not perfectly closed or worn</i>), the integrated board performs a reset and starts a new contact verification cycle; if, after 6 such cycles the problem hasn't been solved, the boiler is blocked.</p> <p>To get the boiler working again, press the "Reset" button (S3) and then make either a d.h.w. or central heating request.</p>	



<p><b>Parasite flame block</b> <i>(from October 2005)</i></p>	<p>Boiler operation is blocked if there is a dispersion in the detection circuit or a malfunction of the flame control that generates an ionisation current lasting at least 20 seconds. To get the boiler working again, press the “Reset” button (S3) and then make either a d.h.w. or central heating request.</p>
<p><b>No ignition block</b></p>	<p>If, within 10 seconds from the start of the ignition cycle the detection electrode (E2) fails to detect the flame on the burner, boiler operation is blocked. The integrated board makes 2 ignition attempts lasting 10 seconds with an interval of 30 seconds after which it shuts down. To get the boiler working again, press the “Reset” button (S3) and then make either a d.h.w. or central heating request. <b>NOTE:</b> The malfunction can be reset up to 5 consecutive times after which the function is inhibited for at least one hour and you gain one attempt each hour; or you gain 5 attempts putting the boiler in the Stand-by (⏻) position or cutting power off to the circuit.</p>
<p><b>Flue pressure switch block (S6)</b></p>	<p>If the flue pressure switch contact opens while the fan is working, the boiler stops. If normal conditions are restored, the boiler restarts without having to be reset. If it closes with the fan off, it does not enable start of the ignition cycle.</p>
<p><b>Safety thermostat block (E4)</b></p>	<p>If the overtemperature safety thermostat contact opens, boiler operation is blocked. To get the boiler working again press the “Reset” (S3) push button and then make either a domestic hot water or central heating request.</p>
<p><b>Insufficient circulation</b></p>	<p>To prevent the water-gas exchanger from overheating in the case of a blocked pump or if there is not much water circulating in the primary circuit, when central heating NTC delivery probe (B1) detects an increase in temperature that exceeds 5°C/second, the burner is switched off. It restarts when delivery temperature drops below 42°C.</p>
<p><b>Post-circulation pump</b></p>	<p>To prevent the water-gas exchanger from overheating, at the end of each central heating, antifreeze or “chimneysweep” request, the circulator (M1) keeps working for 30 seconds.</p>
<p><b>Sealed chamber post ventilation</b></p>	<p>After the burner has been switched off at the end of any type of request, the combustion chamber is washed, keeping the fan working for 30 seconds.</p>
<p><b>NTC probe breakage (B1 and B2)</b></p>	<p>Breakage of the central heating delivery probe (B1) is signalled with the visualisation of error code 05 on the boiler display and stops operation in both the central heating and domestic hot water mode. Breakage of the d.h.w. probe (B2) is signalled with the visualisation of error code 06 on the boiler display and stops operation in the d.h.w. mode but the central heating mode is still allowed.</p>
<p><b>Delivery overtemperature ventilation</b></p>	<p>To prevent the water-gas exchanger from overheating, if the boiler temperature detected by the NTC delivery probe (B1) exceeds 90°C, the fan is switched on until the temperature drops below 85°C.</p>

**Digital user interface.**

The appliance is adjusted and controlled (*burner ignition, temperature setting, flame modulation and diagnostics*) by a microprocessor controlled p.c.b. that can be used, by means

of a digital interface featuring display and push buttons, to display and set operating parameters.

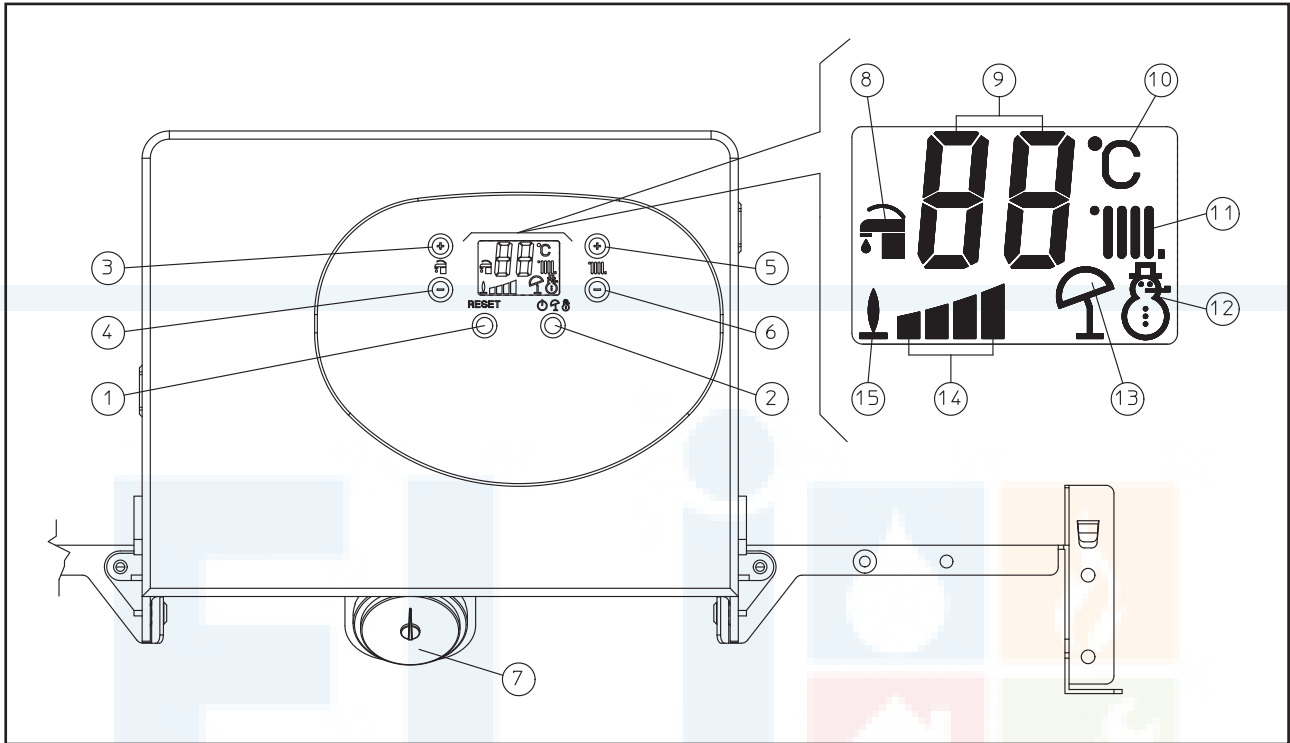

**Operating indicators.**

When the appliance is working normally, the illumination of the display is green which, by way of special symbols, indicates boiler status and functioning mode.

Operating indicators	Symbol
Boiler powered without a flame	Display powered
Boiler in the central heating mode	Symbol 11 on
Boiler in the d.h.w. mode	Symbol 8 on
Burner on	Symbol 15 on
Ongoing chimneysweep function	Symbols 8 and 11 flashing simultaneously

### Operating malfunctions indicated.

In the event of a failure or malfunction, the illumination of the EOLO Star 23 kW display changes colour, going from green to orange if the problem can be rearmed electrically or from green to red if the problem can be rearmed manually.

The relative error codes, given in the following table, flash at the same time on the boiler display.

**\* From October 2005**

Operating malfunctions signalled	Flashing code displayed	Display illumination colour	Remote digital display
No ignition block	01	Red	01
Safety thermostat overtemperature block, flame control malfunction	02	Red	02
Electromechanical contacts *	04	Red	04
NTC delivery probe malfunction	05	Orange	05
NTC d.h.w. probe malfunction	06	Orange	06
Insufficient system pressure	10	Orange	10
Flue pressure switch failure	11	Orange	11
Parasite flame *	20	Red	20
Insufficient circulation	27	Orange	27
D.H.W. anti-leak circuit	28	Orange	28
CRD order anomaly or not compatible	31	Orange	31

### Control and adjustment push buttons.

The EOLO Star 23 kW boiler features push buttons used to select the functioning mode, to set the water temperature in the central heating and d.h.w. modes and to set the boiler's operating parameters.

See the following table for the association of the push buttons:

List of Push Buttons	Description
1	Reset Push Button
2	Stand-by / Summer / Winter Push Button
3	Push button (+) to increase d.h.w. temperature
4	Push button (-) to reduce d.h.w. temperature
5	Push button (+) to increase central heating system water temperature
6	Push button (-) to reduce central heating system water temperature

- press push buttons (1) and (2) simultaneously for about 15 seconds;
- with push buttons (3) and (4) select the parameter you intend changing, indicated in the following table:

List of parameters	Description
P0	Solar panel selection
P1	Selecting the type of gas
P2	Selecting special gas G110
P3	Activating the anti-leak function
P4	Activating post d.h.w. circulation
P5	Minimum central heating power
P6	Maximum central heating power
P7	Central heating ignitions timer
P8	Central heating ramp timer

### Programming the integrated board.

The EOLO Star 23 kW boiler is designed so that some of its operating parameters can be programmed if wanted.

By modifying these parameters the boiler can be adapted to meet one's specific requirements.

To access the programming phase you have to proceed as follows:

- modify the corresponding value with push buttons (5) and (6), consulting the following tables;
- confirm the value set by pressing the Reset Push Button (1) for about 5 seconds;

- press the d.h.w. temperature setting push buttons (3) + and (4) - simultaneously to cancel the operation;

**Note:** if no push buttons are pressed for 30 seconds the operation is cancelled automatically.

**Solar panel selection.** This function is useful for setting the boiler so that it can work with solar panels.

By setting parameter P0 to **on** “solare” mode, the burner shut-down is related to the domestic hot water temperature regulation. In **oF** mode, the burner shut-down occurs at maximum value.

**N.B.:** in combination with a solar valve kit, it is preferable to set the parameter P0 to **on** “solare” mode.

Solar panel selection	
Range of settable values	Parameter
<b>on</b> “solare” - <b>oF</b> (Standard setting)	P0

**Selecting the type of gas.** Setting this function is used to adjust the boiler so it can work with LPG or natural gas.

Selecting the type of gas	
Range of settable values	Parameter
<b>LG</b> (LPG) or <b>nG</b> (Natural Gas) (Standard setting)	P1

**Gas G110 - China gas.** Setting this function is used to adjust the boiler so it can work with the first family gases.

Gas G110 - China Gas (first family gas)	
Range of settable values	Parameter
<b>on</b> - <b>oF</b> (Standard setting)	P2

**Anti-leak function.** This function reduces central heating temperature to 57°C if a d.h.w. circulation is found in the central heating mode.

Activating the anti-leak function	
Range of settable values	Parameter
<b>on</b> (Standard setting) - <b>oF</b>	P3

**Post d.h.w. circulation function.** With the post circulation function active after domestic hot water has been drawn, the pump is kept working for 2.5 seconds in the Winter phase and 1.5 seconds in the Summer phase to reduce the formation of scale.

Activating post d.h.w. circulation	
Range of settable values	Parameter
<b>on</b> (Standard setting) - <b>oF</b>	P4

**Central heating power.** The EOLO Star 23 kW boiler features electronic modulation that adapts boiler power to the real heat requirements of the home. So the boiler works normally in a variable range of gas pressures going from the minimum to maximum central heating power according to the system’s thermal load.

**Note:** the EOLO Star 23 kW boiler is made and calibrated at the nominal output in the central heating phase. But you need about 10 minutes for it to reach the nominal heating output, modifiable by selecting parameter (P6).

**Note:** if the “Minimum central heating power” and “Maximum central heating power” parameters are selected when there is a central heating request, boiler ignition is allowed and powering of the modulation coil with a current equal to the relative value set.

Minimum central heating power	
Range of settable values	Parameter
from <b>0</b> % I <sub>max</sub> . a <b>63</b> % I <sub>max</sub> (factory set at 9.3 kW equivalent to 8,000 kcal/h)	P5

Maximum central heating power	
Range of settable values	Parameter
from <b>0</b> % I <sub>max</sub> . to <b>99</b> % I <sub>max</sub> . (Standard setting)	P6

**Timer settings.** The boiler has an electronic timer that prevents frequent burner ignitions in the central heating mode. The boiler has its own standard timer set at 3 minutes.

Central heating ignitions timer	
Range of settable values	Parameter
from <b>1</b> to <b>10</b> 3 = 3 minutes (Standard setting) 1 = 30 seconds	P7

**Central heating ramp timer.** The boiler carries out a 10 minute ignition ramp to go from minimum power to maximum central heating power.

Central heating ramp timer	
Range of settable values	Parameter
from <b>1</b> a <b>10</b> 10 = 10 minutes (Standard setting) 1 = 30 seconds	P8

**EOLO Star 23 kW operating sequence**

**Central heating phase**

**Domestic hot water phase**

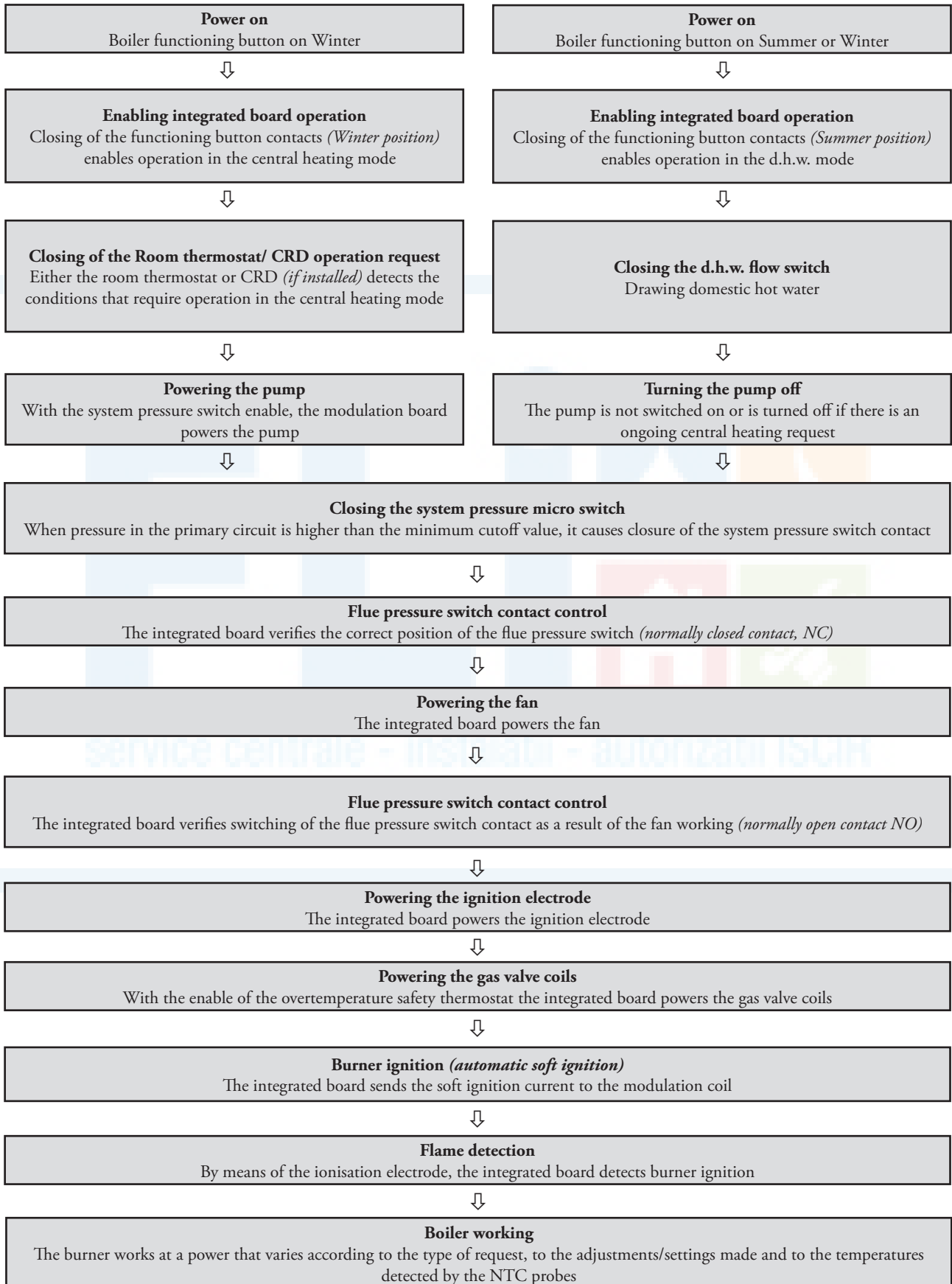

**Technical data.**

**EOLO Star 23 kW technical data.**

Rated heating power	kW (kcal/h)	25,1 (21586)		
Min. heating power	kW (kcal/h)	7,9 (6834)		
Rated heat output (useful)	kW (kcal/h)	23,8 (20485)		
Min. heat output (useful)	kW (kcal/h)	7,0 (6000)		
Useful thermal efficiency at rated output	%	94,9		
Useful thermal efficiency at 30% rated output	%	91,1		
Heat loss at shell with burner On/Off	%	0,4 / 0,54		
Heat loss at flue with burner On/Off	%	4,7 / 0,02		
		G20	G30	G31
Gas nozzle diameter	mm	1,25	0,76	0,76
Supply pressure	mbar (mm H <sub>2</sub> O)	20 (204)	29 (296)	37 (377)
Max. working pressure heating circuit	bar	3		
Max. working temperature heating circuit	°C	90		
Adjustable heating temperature	°C	35 - 80		
Total volume heating expansion tank	l	3,95		
Heating expansion tank precharge	bar	1,0		
Generator water capacity	l	3,5		
Head available with flowrate 1000/h	kPa (m H <sub>2</sub> O)	25,5 (2,6)		
Hot water production available heat output	kW (kcal/h)	23,8 (20485)		
Domestic hot water adjustable temperature	°C	35 - 55		
Domestic circuit flow limiter	l/min	8		
Flow limiter rated delivery min. pressure	bar	1,0		
Domestic circuit min. pressure (dynamic)	bar	0,3		
Domestic circuit max. working pressure	bar	10		
Min. drawing domestic hot water	l/min	1,5		
Drawing capacity in continuous duty (ΔT 30°C)	l/min	11,1		
Specific capacity (ΔT 30°C)	l/min	10,7		
Weight of boiler full	kg	38		
Weight of boiler empty	kg	34		
Electrical connection	V/Hz	230/50		
Rated absorption	A	0,79		
Installed electrical power	W	135		
Power absorbed by circulating pump	W	73		
Power absorbed by fan	W	43		
Appliance electrical system protection	-	IPX4D		
		G20	G30	G31
Mass flow of fumes at rated power	kg/h	52	52	54
Mass flow of fumes at min. power	kg/h	51	42	44
CO <sub>2</sub> at Q. Rated/Min.	%	6,9 / 2,1	8,0 / 3,0	7,7 / 2,8
CO with 0% O <sub>2</sub> at Q. Rated/Min.	ppm	53 / 53	79 / 66	28 / 15
NOX with 0% O <sub>2</sub> at Q. Rated/Min.	ppm	62 / 17	80 / 20	75 / 20
Temperature of fumes at rated power	°C	107	105	109
Temperature of fumes at min. power	°C	83	86	83
NO <sub>x</sub> class	-	3		
NO <sub>x</sub> weighted	mg/kWh	106		
CO weighted	mg/kWh	89		
Type of appliance	C12 / C32 / C42 / C52 / C82 / B22 / B32			
Category	II2H3+			

- The flue temperature values refer to an air inlet temperature of 15°C.
- Data relative to d.h.w. performance refer to a dynamic inlet pressure of 2 bar and an inlet temperature of 15°C; these values are measured at boiler outlet considering that to find these declared values mixing with cold water is necessary.

**EOLO Star 23 kW variable heat output.**

		NATURAL GAS (G20)			BUTANE (G30)			PROPANE (G31)		
HEAT OUTPUT	HEAT OUTPUT	BURNER GAS FLOW RATE	BURNER NOZZLE PRESSURE		BURNER GAS FLOW RATE	BURNER NOZZLE PRESSURE		BURNER GAS FLOW RATE	BURNER NOZZLE PRESSURE	
(kW)	(kcal/h)		(mbar)	(mm H <sub>2</sub> O)		(mbar)	(mm H <sub>2</sub> O)		(mbar)	(mm H <sub>2</sub> O)
23,8	20485	2,66	12,13	123,8	1,98	28,00	285,6	1,95	36,40	371,3
22,1	19000	2,47	10,84	110,6	1,84	25,07	255,7	1,81	32,78	334,4
20,9	18000	2,34	10,01	102,1	1,75	23,20	236,6	1,72	30,45	310,6
19,8	17000	2,22	9,19	93,8	1,65	21,40	218,3	1,63	28,19	287,6
18,6	16000	2,10	8,40	85,7	1,56	19,68	200,8	1,54	26,01	265,3
17,4	15000	1,97	7,63	77,8	1,47	18,03	183,9	1,45	23,89	243,7
16,3	14000	1,85	6,88	70,1	1,38	16,45	167,8	1,36	21,84	222,7
15,1	13000	1,73	6,14	62,6	1,29	14,93	152,3	1,27	19,84	202,4
14,0	12000	1,60	5,42	55,3	1,19	13,47	137,4	1,18	17,90	182,6
12,8	11000	1,48	4,72	48,1	1,10	12,07	123,1	1,09	16,01	163,3
11,6	10000	1,35	4,03	41,1	1,01	10,72	109,4	0,99	14,18	144,6
11,3	9757	1,32	3,86	39,4	0,99	10,40	106,1	0,97	13,74	140,1
9,5	8147	1,12	2,78	28,4	0,83	8,38	85,5	0,82	10,90	111,2
8,1	7000	0,97	2,03	20,7	0,72	7,02	71,6	0,71	8,95	91,3
7,6	6500	0,91	1,71	17,4	0,68	6,45	65,8	0,67	8,12	82,8
7,0	6000	0,84	1,39	14,2	0,63	5,90	60,2	0,62	7,30	74,5

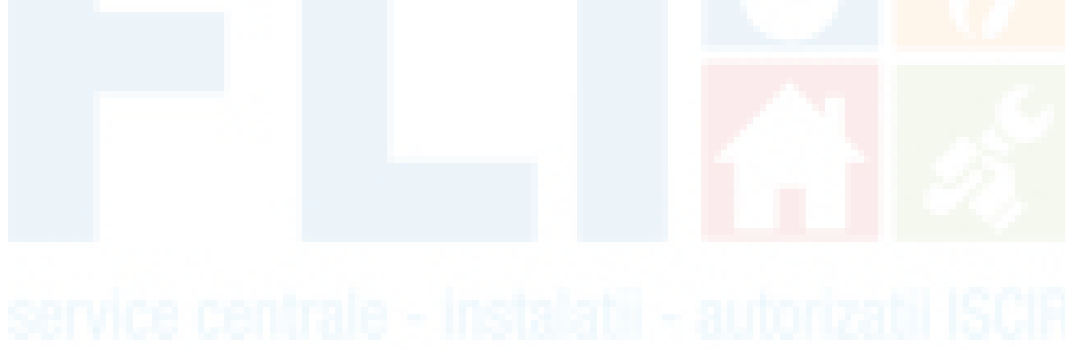



service centrale - instalatii - autorizatii ISCIR